

BOARD OF COUNTY COMMISSIONERS OF BRADFORD COUNTY, FLORIDA

April 7, 2026

9:30 AM

Bradford County Courthouse

945 North Temple Avenue

Starke, Florida 32091

AGENDA

1. Chair to call meeting to order.

ACTION

2. Public Hearing – Zoning Change

- A. Public Hearing to Consider approval of Z 25-05 (Mimosa Tree Investments, LLC.) – Zoning Change for Bradford County Parcel Number 04734-0-00200 and 04739-0-00000.

AN ORDINANCE OF BRADFORD COUNTY, FLORIDA, AMENDING ORDINANCE 96-07, BRADFORD COUNTY LAND DEVELOPMENT REGULATIONS, AS AMENDED; RELATING TO AN AMENDMENT TO THE OFFICIAL ZONING ATLAS OF THE BRADFORD COUNTY LAND DEVELOPMENT REGULATIONS, AS AMENDED, PURSUANT TO APPLICATION NUMBER Z25-05 SUBMITTED BY THE PROPERTY OWNER OF SAID ACREAGE; PROVIDING FOR REZONING FROM AGRICULTURE – 2 (A-2) AND COMMERCIAL TO INDUSTRIAL (I) OF CERTAIN LANDS WITHIN THE UNINCORPORATED LIMITS OF BRADFORD COUNTY, FLORIDA; PROVIDING SEVERABILITY; REPEALING ALL ORDINANCES IN CONFLICT; AND PROVIDING AN EFFECTIVE DATE.

- i. Open Public Hearing – Public Comments
- ii. Close Public Hearing
- iii. Motion and Vote

- B. Public hearing to Consider approval of Z 25-06 (Mimosa Tree Investments, LLC.) – Zoning Change for Bradford County Parcel Number 04776-0-00000.

AN ORDINANCE OF BRADFORD COUNTY, FLORIDA, AMENDING ORDINANCE 96-07, BRADFORD COUNTY LAND DEVELOPMENT REGULATIONS, AS AMENDED; RELATING TO AN AMENDMENT TO THE OFFICIAL ZONING ATLAS OF THE BRADFORD COUNTY LAND DEVELOPMENT REGULATIONS, AS AMENDED, PURSUANT TO APPLICATION NUMBER Z25-06 SUBMITTED BY THE PROPERTY OWNER OF SAID ACREAGE; PROVIDING FOR REZONING FROM AGRICULTURE – 2 (A-2) TO INDUSTRIAL (I) OF CERTAIN LANDS

WITHIN THE UNINCORPORATED LIMITS OF BRADFORD COUNTY, FLORIDA; PROVIDING SEVERABILITY; REPEALING ALL ORDINANCES IN CONFLICT; AND PROVIDING AN EFFECTIVE DATE.

- i. Open Public Hearing – Public Comments
- ii. Close Public Hearing
- iii. Motion and Vote

3. Public Hearing – Enactment of Ordinance – First Reading

AN ORDINANCE OF THE BOARD OF COUNTY COMMISSIONERS OF BRADFORD COUNTY, FLORIDA, AMENDING THE PURCHASING POLICY, SPECIFICALLY CHAPTER 2 – ADMINISTRATION, ARTICLE IV - PURCHASING PROCEDURES, SECTIONS 2-151 THROUGH 2-172 OF THE BRADFORD COUNTY CODE OF ORDINANCES; AND PROVIDING AN EFFECTIVE DATE.

- i. Open Public Hearing – Public Comments
- ii. Close Public Hearing
- iii. Discussion

4. Public Comments

- Three (3) minutes per speaker;
- State your name and address into the record before addressing the board;
- Address your questions to the board, not county staff;
- Refrain from demands for an immediate board response; Commissioners will not engage with speakers during public comments; and
- No boisterous behavior, personal, impertinent, or slanderous remarks.

ACTION

5. Approval of Consent Agenda

- A. State Housing Initiatives Partnership Program (SHIP) Rehabilitation Loan File #2022-3 (Lemire) in an amount not to exceed **\$35,000**.
- B. Bradford County Board of County Commissioners meeting minutes from March 3, 2026.
- C. Bradford County Board of County Commissioners meeting minutes from March 19, 2026.
- D. Confirmation of (Burn Ban)
AN EMERGENCY ORDER ISSUED BY THE BOARD OF COUNTY COMMISSIONERS OF BRADFORD COUNTY, FLORIDA, DECLARING A LOCAL STATE OF EMERGENCY AND IMPOSING A BURN BAN IN BRADFORD COUNTY, FLORIDA PURSUANT TO SECTION 252.38, FLORIDA STATUTES; PROVIDING FOR AN IMMEDIATE EFFECTIVE DATE. (March 17, 2026 – March 23, 2026)

- E. Confirmation of (Burn Ban)
AN EMERGENCY ORDER ISSUED BY THE BOARD OF COUNTY, COMMISSIONERS OF BRADFORD COUNTY, FLORIDA, DECLARING A LOCAL STATE OF EMERGENCY AND IMPOSING A BURN BAN IN BRADFORD COUNTY, FLORIDA PURSUANT TO SECTION 252.38, FLORIDA STATUTES; PROVIDING FOR AN IMMEDIATE EFFECTIVE DATE. (March 24, 2026 – March 30, 2026)
- F. Confirmation of (Burn Ban)
AN EMERGENCY ORDER ISSUED BY THE BOARD OF COUNTY, COMMISSIONERS OF BRADFORD COUNTY, FLORIDA, DECLARING A LOCAL STATE OF EMERGENCY AND IMPOSING A BURN BAN IN BRADFORD COUNTY, FLORIDA PURSUANT TO SECTION 252.38, FLORIDA STATUTES; PROVIDING FOR AN IMMEDIATE EFFECTIVE DATE. (March 31, 2026 – April 6, 2026)
- G. Site Access Agreement with Florida Department of Environmental Protection for monitoring of the “Douglas Building” Property – 14281 US Hwy 301 South, Starke, Florida.
- H. Updated Task Work Order with North Florida Professional Services for Zoning Services.
- I. Confirmation of Bernadette Fisher as Zoning Director.
- J. Disbursement of \$6,093.41 of Federal Emergency Management Agency (FEMA) Public Assistance (PA) claim for Bradford County Public Works “cut & toss” operations during Hurricane Helene (DR-4828-FL).
- K. A resolution to authorize staff to submit a grant application to Florida Fish and Wildlife Conservation Commission for the construction of the Cypress Run Boat Ramp.
A RESOLUTION OF THE BOARD OF COUNTY COMMISSIONERS OF BRADFORD COUNTY, FLORIDA, AUTHORIZING THE SUBMISSION OF AN APPLICATION FOR, AND THE ADMINISTRATION OF, A BOATING ACCESS GRANT FROM FLORIDA FISH AND WILDLIFE CONSERVATION COMMISSION FLORIDA BOATING IMPROVEMENT PROGRAM; PROVIDING DIRECTION TO STAFF AND PROVIDING AN EFFECTIVE DATE.
- L. TDC – Approval for purchase of Polaris Ranger (MERV) for firefighting operations not to exceed \$35,000. (up to \$25,000 TDC Funds/ \$10,000 Private Donation)
- M. First Amendment to the MOU between the Florida Department of Health and Bradford County for the continued clerical staff support for the Onsite Sewage Wastewater Treatment Disposal Program (OSTDS).

Presentation

- 6. Partnership for Strong Families - Director of Development and Engagement, Amanda Demaria
 - A. Proclamation Declaring April 2026 as “Child Abuse Prevention Month”

Presentation

7. Clay County Commissioner, Betsy Condon

A. Lake Geneva Project

ACTION

8. Keystone Collection Site Air Burner Purchase (\$213,862.53) as a Capital Improvement Item Replacing an Approved Bucket Truck Purchase (\$300,000.00)

Discussion

9. Discussion of “Douglas” Building Property Options

A. Potential Lease with Bradford County Sheriff’s Office for the purpose of installation of a temporary ICE detentionment facility.

B. Other Lease or Marketing Options

10. Clerk Reports – Denny Thompson, Clerk to the Board and Clerk of the Circuit Court

A. Appoint a citizen member to serve on the Bradford County Value Adjustment Board.

B. Notice of lands available for taxes. Direction needed from the board on its desire to purchase or waive is right to purchase the available land for taxes.

11. Sheriff Reports – Gordon Smith, Sheriff

12. County Manager Reports – County Manager, Scott Kornegay

A. Introduction of Bernadette Fisher, Zoning Director

B. Legislative Update

13. County Attorney Reports – Rob Bradley

14. Commissioner’s Comments

15. Chair’s Comments

* Budget Workshop to follow this meeting at 10:30 AM

UPCOMING MEETINGS:

Board of County Commissioners: Thursday, April 16, 2026 @ 6:30 PM

Board of County Commissioners: Tuesday, May 5, 2026 @ 9:30 AM

Budget Workshop: Thursday, May 21, 2026 @ 5:30 PM

Board of County Commissioners: Thursday, May 21, 2026 @ 6:30 PM

NOTICE:

Pursuant to Section 286.0105, Florida Statutes, notice is hereby provided that, if a person decides to appeal any decision made by the Board of County Commissioners of Bradford County, Florida with respect to any matter considered at this meeting or hearing, he or she will need a record of the proceedings, and that, for such purpose, he or she may need to ensure that a verbatim record of the proceedings is made, which record includes the testimony and evidence upon which the appeal is to be based.

BOARD OF COUNTY COMMISSIONERS OF BRADFORD COUNTY, FLORIDA

AGENDA ITEM INFORMATION SHEET

DATE: April 7th, 2026

AGENDA ITEM: Public Hearing to Consider approval of Z 25-05 (Mimosa Tree Investments , LLC.) – Zoning Change for Bradford County Parcel Number 04734-0-00200 and 04739-0-00000.

AN ORDINANCE OF BRADFORD COUNTY, FLORIDA, AMENDING ORDINANCE 96-07, BRADFORD COUNTY LAND DEVELOPMENT REGULATIONS, AS AMENDED; RELATING TO AN AMENDMENT TO THE OFFICIAL ZONING ATLAS OF THE BRADFORD COUNTY LAND DEVELOPMENT REGULATIONS, AS AMENDED, PURSUANT TO APPLICATION NUMBER Z25-05 SUBMITTED BY THE PROPERTY OWNER OF SAID ACREAGE; PROVIDING FOR REZONING FROM AGRICULTURE – 2 (A-2) AND COMMERCIAL TO INDUSTRIAL (I) OF CERTAIN LANDS WITHIN THE UNINCORPORATED LIMITS OF BRADFORD COUNTY, FLORIDA; PROVIDING SEVERABILITY; REPEALING ALL ORDINANCES IN CONFLICT; AND PROVIDING AN EFFECTIVE DATE.

DEPARTMENT : Zoning

PURPOSE/DESCRIPTION:

Mimosa Tree Investments, LLC, seek approvals to amend the Official Zoning Atlas of Bradford County, Florida, relating to the Rezoning of Twenty-one (21) acres, more or less, Pursuant to an application, Z 25-05, by the property owners of said acreage, providing for Changing the Zoning District from **AGRICULTURAL-2 and COMMERCIAL to INDUSTRIAL**.

ASSOCIATED COST/ REVENUE GENERATED: \$ 0.00

BUDGET LINE (G/L #): N/A

TO BE COMPLETED BY THE COUNTY MANAGER'S OFFICE

RECOMMENDED ACTION:

Call for public comments. Make a motion to change the current Zoning District from Agricultural-2 and Commercial to Industrial.

RECOMMENDED MOTION:

Based on the NFPS, Inc. recommendation, make a motion to approve Z 25-05.

ORDINANCE NO. 2026- 01

AN ORDINANCE OF BRADFORD COUNTY, FLORIDA, AMENDING ORDINANCE 96-07, BRADFORD COUNTY LAND DEVELOPMENT REGULATIONS, AS AMENDED; RELATING TO AN AMENDMENT TO THE OFFICIAL ZONING ATLAS OF THE BRADFORD COUNTY LAND DEVELOPMENT REGULATIONS, AS AMENDED, PURSUANT TO APPLICATION NUMBER Z25-05 SUBMITTED BY THE PROPERTY OWNER OF SAID ACREAGE; PROVIDING FOR REZONING FROM AGRICULTURE – 2 (A-2) AND COMMERCIAL TO INDUSTRIAL (I) OF CERTAIN LANDS WITHIN THE UNINCORPORATED LIMITS OF BRADFORD COUNTY, FLORIDA; PROVIDING SEVERABILITY; REPEALING ALL ORDINANCES IN CONFLICT; AND PROVIDING AN EFFECTIVE DATE.

WHEREAS, Section 125.01, Florida Statutes, as amended, empowers the Board of County Commissioners of Bradford County, Florida, hereinafter referred to as the County Commission, to prepare and adopt land development regulations;

WHEREAS, Sections 163.3161 through 163.3248, Florida Statutes, as amended, the Community Planning Act, requires the County Commission to prepare and adopt regulations concerning the use of land and water;

WHEREAS, an application for an amendment, as described below, has been filed with the County;

WHEREAS, the County Commission has been designated as the Planning and Zoning Board of Bradford County, Florida, hereinafter referred to as the Planning and Zoning Board, has been designated as the Local Planning Agency of Bradford County, Florida, hereinafter referred to as the Local Planning Agency;

WHEREAS, pursuant to Section 163.3174, Florida Statutes, as amended, and the Land Development Regulations, the County Commission, serving as the Planning and Zoning Board, and the Local Planning Agency, held the required public hearing, with public notice having been provided, on said application for an amendment, as described below, and at said public hearing, the County Commission, serving as the Planning and Zoning Board, and the Local Planning Agency, reviewed and considered all comments received during said public hearing and the Concurrency Management Assessment concerning said application for an amendment, as described below, and recommended to the County Commission approval of said application for an amendment, as described below;

WHEREAS, pursuant to Section 125.01, Florida Statutes, as amended, the County Commission held the required public hearings, with public notice having been provided, on said application for an amendment, as described below, and at said public hearings, the County Commission reviewed and considered all comments received during the public hearings, including the recommendation of the County Commissioner, serving as the Planning and Zoning Board, and the Local Planning Agency, and the Concurrency Management Assessment concerning said application for an amendment, as described below;

WHEREAS, the County Commission has determined and found that approval of said application for an amendment, as described below, would promote the public health, safety, morals, order, comfort, convenience, appearance, prosperity or general welfare.

NOW, THEREFORE, BE IT ORDAINED BY THE BOARD OF COUNTY COMMISSIONERS OF BRADFORD COUNTY, FLORIDA, AS FOLLOWS:

Section 1. Pursuant to an application, Z25-05, by Mimosa Tree Investments, LLC, applicant and property owner, to amend the Official Zoning Atlas of the Land Development Regulations by amending the zoning district of certain lands from AGRICULTURE – 2 (A-2) to INDUSTRIAL (I) for the property described, as follows:

A PARCEL OF LAND LYING IN SECTIONS 6 & 7, OF TOWNSHIP 8 SOUTH, RANGE 22 EAST, AND IN LOTS 3, 4, 5, 6, & 7 OF DAVIS BROTHERS AND TRUBY'S SUB-DIVISION AS PER PLAT RECORDED IN DEED BOOK E, PAGE 680 OF THE PUBLIC RECORDS OF BRADFORD COUNTY, FLORIDA; SAID PARCEL BEING MORE PARTICULARLY DESCRIBED AS FOLLOWS:

COMMENCE AT A CONCRETE MONUMENT (3'X3' NO ID) FOUND AT THE SE CORNER OF SAID SECTION 6 (NE CORNER OF SEC. 7) A DISTANCE OF 830.18 FEET TO SET ½" IRON ROD (LB 4012); THENCE SOUTH 88 DEGREES 05 MINUTES 19 SECONDS WEST, 523.00 FEET TO A SET ½" IRON ROD (LB 4017); THENCE NORTH 07 DEGREES 18 MINUTES 21 SECONDS EAST, 70.00 FEET TO A FOUND 3"X3" CONCRETE MONUMENT (LB 4012); THENCE SOUTH 87 DEGREES 51 MINUTES 39 SECONDS WEST, 822.62 FEET TO A 3"X"3" CONCRETE MONUMENT (LB 4012) FOUND AT THE EASTERLY BOUNDARY OF THE RIGHT OF WAY OF STATE ROAD 200 (U.S. 301); THENCE NORTH 07 DEGREES 29 MINUTES 05 SECONDS EAST, ALONG SAID EASTERLY BOUNDARY 926.83 FEET TO A CONCRETE MONUMENT (NO ID); THENCE NORTH 85 DEGREES 29 MINUTES 32 SECONDS EAST, 1192.81 FEET TO A FOUND 3"X3" CONCRETE MONUMENT (NO ID) ON THE EASTERLY BOUNDARY OF SAID SECTION 6; THENCE SOUTH 01 DEGREES 39 MINUTES 35 SECONDS EAST, ALONG SAID BOUNDARY 141.71 FEET TO THE POINT OF BEGINNING.

AND ALSO,

A STRIP OF LAND 30.0 FEET IN WIDTH LYING BETWEEN LOTS 3, 4, 5, AND 6 IN DAVIS BROTHERS, TRUBY'S SUBDIVISION AS RECORDED IN DEED BOOK E, PAGE 680 OF THE PUBLIC RECORDS OF BRADFORD COUNTY, FLORIDA. SAID STRIP EXTENDING EAST FROM THE EASTERLY BOUNDARY OF THE RIGHT OF WAY OF STATE ROAD 200, U.S. 301 TO THE EASTERLY BOUNDARY OF SECTION 7, TOWNSHIP 7 SOUTH, RANGE 22 EAST.

CONTAINING 21.15 ACRES, MORE OR LESS

TAX PARCEL NUMBERS 04734-0-00200 AND 04739-0-00000

Section 2. Severability. If any provision or portion of this ordinance is declared by any court of competent jurisdiction to be void, unconstitutional or unenforceable, then all remaining provisions and portions of this ordinance shall remain in full force and effect.

Section 3. Conflict. All ordinances or portions of ordinances in conflict with this ordinance are hereby repealed to the extent of such conflict.

Section 4. Pursuant to Section 125.01, Florida Statutes, as amended, a certified copy of this ordinance shall be filed with the Florida Department of State by the Clerk of the Court of Bradford County, Florida, within ten (10) days after enactment by the Bradford County Board of County Commissioners.

Section 5. Effective Date. This Ordinance shall take effect immediately after its passage and adoption. No development orders, development permit, or land uses dependent on this Amendment may be issued or commenced before this Amendment has become effective.

Section 6. Authority. This ordinance is adopted pursuant to the authority granted by Section 125.01, Florida Statutes, as amended, and Sections 163.3161 through 163.3248, Florida Statutes, as amended.

PASSED AND DULY ADOPTED, in regular session with a quorum present and voting,
by the County Commission on the _____ day of _____ 2026.

BOARD OF COUNTY COMMISSIONERS OF
BRADFORD COUNTY, FLORIDA

Attest:

Denny Thompson
Clerk of Court

Carolyn Spooner
Chairwoman

APPROVED FOR FORM AND LEGALITY:

Rob Bradley
County Attorney

BOARD OF COUNTY COMMISSIONERS OF BRADFORD COUNTY, FLORIDA

AGENDA ITEM INFORMATION SHEET

DATE: April 7th 2026

AGENDA ITEM: Public hearing to Consider approval of Z 25-06 (Mimosa Tree Investments , LLC.) – Zoning Change for Bradford County Parcel Number 04776-0-00000.

AN ORDINANCE OF BRADFORD COUNTY, FLORIDA, AMENDING ORDINANCE 96-07, BRADFORD COUNTY LAND DEVELOPMENT REGULATIONS, AS AMENDED; RELATING TO AN AMENDMENT TO THE OFFICIAL ZONING ATLAS OF THE BRADFORD COUNTY LAND DEVELOPMENT REGULATIONS, AS AMENDED, PURSUANT TO APPLICATION NUMBER Z25-06 SUBMITTED BY THE PROPERTY OWNER OF SAID ACREAGE; PROVIDING FOR REZONING FROM AGRICULTURE – 2 (A-2) TO INDUSTRIAL (I) OF CERTAIN LANDS WITHIN THE UNINCORPORATED LIMITS OF BRADFORD COUNTY, FLORIDA; PROVIDING SEVERABILITY; REPEALING ALL ORDINANCES IN CONFLICT; AND PROVIDING AN EFFECTIVE DATE.

DEPARTMENT: Zoning

PURPOSE/DESCRIPTION:

Mimosa Tree Investments, LLC, seek approvals to amend the Official Zoning Atlas of Bradford County, Florida, relating to the Rezoning of Sixteen (16) acres, more or less, Pursuant to an application, Z 25-06, by the property owners of said acreage, providing for Changing the Zoning District from **AGRICULTURAL-2 to INDUSTRIAL**.

ASSOCIATED COST/ REVENUE GENERATED: \$ 0.00

BUDGET LINE (G/L #): N/A

TO BE COMPLETED BY THE COUNTY MANAGER'S OFFICE

RECOMMENDED ACTION:

Call for public comments. Make a motion to change the current Zoning District from Agricultural-2 to Industrial.

RECOMMENDED MOTION:

Based on the NFPS, Inc. recommendation, make a motion to approve Z 25-06.

ORDINANCE NO. 2026-02

AN ORDINANCE OF BRADFORD COUNTY, FLORIDA, AMENDING ORDINANCE 96-07, BRADFORD COUNTY LAND DEVELOPMENT REGULATIONS, AS AMENDED; RELATING TO AN AMENDMENT TO THE OFFICIAL ZONING ATLAS OF THE BRADFORD COUNTY LAND DEVELOPMENT REGULATIONS, AS AMENDED, PURSUANT TO APPLICATION NUMBER Z25-06 SUBMITTED BY THE PROPERTY OWNER OF SAID ACREAGE; PROVIDING FOR REZONING FROM AGRICULTURE – 2 (A-2) TO INDUSTRIAL (I) OF CERTAIN LANDS WITHIN THE UNINCORPORATED LIMITS OF BRADFORD COUNTY, FLORIDA; PROVIDING SEVERABILITY; REPEALING ALL ORDINANCES IN CONFLICT; AND PROVIDING AN EFFECTIVE DATE.

WHEREAS, Section 125.01, Florida Statutes, as amended, empowers the Board of County Commissioners of Bradford County, Florida, hereinafter referred to as the County Commission, to prepare and adopt land development regulations;

WHEREAS, Sections 163.3161 through 163.3248, Florida Statutes, as amended, the Community Planning Act, requires the County Commission to prepare and adopt regulations concerning the use of land and water;

WHEREAS, an application for an amendment, as described below, has been filed with the County;

WHEREAS, the County Commission has been designated as the Planning and Zoning Board of Bradford County, Florida, hereinafter referred to as the Planning and Zoning Board, has been designated as the Local Planning Agency of Bradford County, Florida, hereinafter referred to as the Local Planning Agency;

WHEREAS, pursuant to Section 163.3174, Florida Statutes, as amended, and the Land Development Regulations, the County Commission, serving as the Planning and Zoning Board, and the Local Planning Agency, held the required public hearing, with public notice having been provided, on said application for an amendment, as described below, and at said public hearing, the County Commission, serving as the Planning and Zoning Board, and the Local Planning Agency, reviewed and considered all comments received during said public hearing and the Concurrency Management Assessment concerning said application for an amendment, as described below, and recommended to the County Commission approval of said application for an amendment, as described below;

WHEREAS, pursuant to Section 125.01, Florida Statutes, as amended, the County Commission held the required public hearings, with public notice having been provided, on said application for an amendment, as described below, and at said public hearings, the County Commission reviewed and considered all comments received during the public hearings, including the recommendation of the County Commissioner, serving as the Planning and Zoning Board, and the Local Planning Agency, and the Concurrency Management Assessment concerning said application for an amendment, as described below;

WHEREAS, the County Commission has determined and found that approval of said application for an amendment, as described below, would promote the public health, safety, morals, order, comfort, convenience, appearance, prosperity or general welfare.

NOW, THEREFORE, BE IT ORDAINED BY THE BOARD OF COUNTY COMMISSIONERS OF BRADFORD COUNTY, FLORIDA, AS FOLLOWS:

Section 1. Pursuant to an application, Z25-06, by Mimosa Tree Investments, LLC, applicant and property owner, to amend the Official Zoning Atlas of the Land Development Regulations by amending the zoning district of certain lands from AGRICULTURE – 2 (A-2) to INDUSTRIAL (I) for the property described, as follows:

A PARCEL OF LAND LYING IN SECTION 8 OF TOWNSHIP 7 SOUTH, RANGE 22 EAST, AND IN DAVIS BROTHERS AND TRUBY'S SUBDIVISION AS PER PLAT RECORDED IN DEED BOOK E, PAGE 680 OF THE PUBLIC RECORDS OF BRADFORD COUNTY, FLORIDA; SAID PARCEL BEING MORE PARTICULARLY DESCRIBED AS FOLLOWS:

THE NORTH ½ OF THE NORTHWEST ¼ OF SAID SECTION 8, LESS AND EXCEPT THE FOLLOWING DESCRIBED PARCEL:

COMMENCE AT THE NORTHWEST CORNER OF SAID NORTH ½ AND RUN SOUTH 01 DEGREES 17 MINUTES 09 SECONDS EAST, ALONG THE WESTERLY BOUNDARY THEREOF, 36.62 FEET TO THE POINT OF BEGINNING. FROM POINT OF BEGINNING THUS DESCRIBED CONTINUE SOUTH 01 DEGREES 17 MINUTES 09 SECONDS EAST, ALONG SAID WESTERLY BOUNDARY, 475.36 FEET; THENCE NORTH 88 DEGREES 07 MINUTES 47 SECONDS EAST, 19.91 FEET; THENCE NORTH 64 DEGREES 04 MINUTES 16 SECONDS EAST, 342.36 FEET; THENCE NORTH 01 DEGREES 30 MINUTES 14 SECONDS WEST, 320.39 FEET; THENCE NORTH 89 DEGREES 12 MINUTES 04 SECONDS WEST, 330.22 FEET TO THE POINT OF BEGINNING.

CONTAINING 16.94 ACRES, MORE OR LESS

TAX PARCEL NUMBERS 04776-0-00000

Section 2. Severability. If any provision or portion of this ordinance is declared by any court of competent jurisdiction to be void, unconstitutional or unenforceable, then all remaining provisions and portions of this ordinance shall remain in full force and effect.

Section 3. Conflict. All ordinances or portions of ordinances in conflict with this ordinance are hereby repealed to the extent of such conflict.

Section 4. Pursuant to Section 125.01. Florida Statutes, as amended, a certified copy of this ordinance shall be filed with the Florida Department of State by the Clerk of the Court of Bradford County, Florida, within ten (10) days after enactment by the Bradford County Board of County Commissioners.

Section 5. Effective Date. This Ordinance shall take effect immediately after its passage and adoption. No development orders, development permit, or land uses dependent on this

Amendment may be issued or commenced before this Amendment has become effective.

Section 6. Authority. This ordinance is adopted pursuant to the authority granted by Section 125.01, Florida Statutes, as amended, and Sections 163.3161 through 163.3248, Florida Statutes, as amended.

PASSED AND DULY ADOPTED, in regular session with a quorum present and voting,
by the County Commission on the _____ day of _____ 2026.

BOARD OF COUNTY COMMISSIONERS OF
BRADFORD COUNTY, FLORIDA

Attest:

Denny Thompson
Clerk of Court

Carolyn Spooner
Chairwoman

APPROVED FOR FORM AND LEGALITY:

Rob Bradley
County Attorney

BOARD OF COUNTY COMMISSIONERS OF BRADFORD COUNTY, FLORIDA

AGENDA ITEM INFORMATION SHEET

DATE: April 7, 2026

AGENDA ITEM PUBLIC HEARING – ENACTMENT OF ORDINANCE

AN ORDINANCE OF THE BOARD OF COUNTY COMMISSIONERS OF BRADFORD COUNTY, FLORIDA, AMENDING THE PURCHASING POLICY, SPECIFICALLY CHAPTER 2 – ADMINISTRATION, ARTICLE IV - PURCHASING PROCEDURES, SECTIONS 2-151 THROUGH 2-172 OF THE BRADFORD COUNTY CODE OF ORDINANCES; AND PROVIDING AN EFFECTIVE DATE.

- Open Public Hearing
- Call for Public Comments
- Close Public Hearing
- Call for Motion and Vote

DEPARTMENT: County Manager

PURPOSE: Updating specific sections of the Purchasing Policy for the Board of County Commissioners. The following changes are implemented:

Article IV Section
2-161 (2)

Currently States
“...and where feasible, an attempt shall be made to obtain three telephone quotes.”

Change Needed
Remove fully. No quotes needed for an emergency.

2-161 (5)

“A purchase order should be obtained as soon as is practicable...”

Remove all (5), no purchase order is needed.

2-156

Local Preference

Local preference should change to only offered if the local bidder is within 5% of the low bid. If not, the bid will go to the low bidder. Update to "Chair" β Is it possible to do this just for this section (purchasing) since this is part of the whole county code?

Full Document

"Chairman"

ASSOCIATED COST(S):

BUDGET LINE (G/L #):

ORDINANCE 2026 -

AN ORDINANCE OF THE BOARD OF COUNTY COMMISSIONERS OF BRADFORD COUNTY, FLORIDA, AMENDING THE PURCHASING POLICY, SPECIFICALLY CHAPTER 2 – ADMINISTRATION, ARTICLE IV - PURCHASING PROCEDURES, SECTIONS 2-151 THROUGH 2-172 OF THE BRADFORD COUNTY CODE OF ORDINANCES; AND PROVIDING AN EFFECTIVE DATE.

WHEREAS, the Board of County Commissioners of Bradford County Florida adopted previously a purchasing policy as set forth in Ordinance 2013-10; and

WHEREAS, the Board of County Commissioners of Bradford County Florida wishes to amend the purchasing policy; and

NOW, THEREFORE, BE IT ORDAINED by the Board of County Commissioners of Bradford County, Florida, as follows:

- 1. ADOPTION AND INCORPORATION OF RECITALS.** The Board of County Commissioners of Bradford County, Florida hereby adopts the above recitals and incorporates them herein as a part of this Ordinance.
- 2. CODE AMENDED.** The Bradford County Code of Ordinances is hereby amended, specifically Chapter 2 – Administration, Article IV – Purchasing Procedures, Sections 2-151 through 2-172, as follows:

ARTICLE IV. - PURCHASING PROCEDURES

Sec. 2-151. - Short title.

This article shall hereafter be known as the Bradford County Purchasing Code and is enacted under the home rule powers of the board of county commissioners, pursuant to F.S. § 125.01 and related statutory authority.

Sec. 2-152. - Purpose.

The purpose and intent of this article is to:

- (1) Simplify, clarify and modernize the law governing purchasing by the county;
- (2) Permit the continued development of purchasing policies and practices;
- (3) Provide for increased public confidence in the procedures followed by the county in public purchasing;

- (4) Provide increased economy in county purchasing activities and to maximize to the fullest extent practicable the purchasing value of public funds of the county; and
- (5) Provide safeguards for the maintenance of a purchasing system of quality and integrity in the county.
- (6) Ensure compliance by Bradford County with F.S. chs. 125 and 287, as well as any other relevant provisions of Federal or state law.

Sec. 2-153. - Definitions.

The following words, terms and phrases, when used in this article, shall have the meanings ascribed to them in this section, except where the context clearly indicates a different meaning.

Business shall mean any corporation, partnership, individual, sole proprietorship, joint-stock company, joint venture, or any other private legal entity.

Change order shall mean a written order, amending the scope of, amount, or correcting errors, omissions, or discrepancies in a contract or purchase order.

Competitive sealed proposal shall mean a method which requires the vendor to provide a detailed proposal in response to the specifications, which may be more general in nature, and usually results in a contractual agreement. This method allows for negotiation in scope, price, and delivery, whereas the sealed bid process allows no substantial changes. Proposals under this process are solicited through a request for competitive sealed proposals.

Contract shall mean all types of agreements between third parties and the county, regardless of what they may be called, for the purchase or disposal of supplies, services, materials, equipment or construction.

Contract modification shall mean any written alteration in specifications, delivery point, rate of delivery, period of performance, price, quantity, or other provisions of any contract accomplished by mutual action or agreement of the parties to the contract.

Contractor shall mean any person having a contract with the county.

Invitation to bid shall mean all documents, whether attached or incorporated by reference, used for soliciting sealed bids. Once bids are opened by the county, no changes in scope or price shall be allowed.

Person shall mean any business, individual, committee, club or other organization, or group of individuals.

Purchase order shall mean that contractual document whereby the county requests that a contract be entered into for a specified need, and may include, but not be

limited to, the technical description of the requested item, delivery schedule, transportation, criteria for evaluation, suggested sources of supply, and information supplied for the making of any written determination required by this article.

Purchasing shall mean buying, procuring, renting, leasing, or otherwise acquiring any materials, supplies, services, construction, or equipment. It also includes all functions that pertain to the obtaining of any material, supplies, construction, and equipment.

Request for proposals shall mean all documents, whether attached or incorporated by reference, utilized for soliciting proposals.

Request for quotation shall mean a method of soliciting written prices by either telephone or mail which incorporates specifications, terms, and conditions.

Request for statements of qualifications shall mean all documents, whether attached or incorporated by reference, utilized for soliciting statements or qualifications. This method shall be used for acquisition of professional services exceeding \$25,000.00, except as stated in F.S. § 287.055, and in this article, and shall require vendors to submit written qualifications for the proposed project which would typically include capabilities, adequacy of personnel, past record, experience, whether the firm is a certified minority business enterprise as defined by the Florida Small and Minority Business Assistance Act of 1985 and such other factors required by the county. Pricing shall not be made a part of the vendor submittal. This method allows for negotiation in scope, price, delivery, terms, and results in a contractual agreement. Qualifications may be solicited through a request for proposals.

Responsible bidder or offeror shall mean a person who has the capability, in all respects, to perform fully the contract requirements, and the integrity and reliability which will assure good faith performance.

Responsive bidder shall mean a person who has submitted a bid which conforms in all material respects to an invitation to bid.

Specification shall mean any description of the physical or functional characteristics of the nature of a material, supply, service, construction or equipment item. It may include a description of any requirement for inspection, testing, or preparing a material, supply, service, construction or equipment item for delivery.

Sec. 2-154. - Application.

- (a) This article shall apply only to contracts solicited or entered into after the effective date of the ordinance from which this article derives, unless the parties agree to its application to a contract solicited or entered into prior to said date.

- (b) This article shall apply to county purchasing activities involving materials, supplies, services, construction and equipment. The provisions of this article shall not be mandatory with regard to purchases from the state or other political subdivisions or purchases made pursuant to F.S. §287.055.
- (c) All purchases by the board of county commissioners, and all departments thereunder, shall be for goods and services that serve a county purpose and for which there are budget monies available for the purchase. All purchases for goods and services greater than \$1,000.00 shall be made by purchase order issued prior to said purchase, unless the purchase is made in a state of emergency, pursuant to those rules or procedure established by the county manager or clerk of court as is established pursuant to section 2-170.

Sec. 2-155. - Designation of county manager as purchasing manager.

- (a) The board designates the county manager to serve as purchasing manager, who shall serve as the central purchasing officer of the county.
- (b) The initial purchasing agent shall be the county clerk of court who also serves as clerk to the board.
- (c) Consistent with the provisions of this article, the county manager or his designee shall be authorized to:
 - (1) Purchase or supervise the purchasing of all supplies, services, materials, equipment, and construction needed by the county;
 - (2) Sell, trade or otherwise dispose of surplus supplies, materials and equipment belonging to the county; and
 - (3) Ensure that there are budgeted monies available to fund all purchase orders.

Sec. 2-156. - Local preference.

- (a) The board shall make every reasonable effort, when permissible and feasible under the facts and circumstances as presented on a case-by-case basis, and when the local bidder's response is no more than five percent (5%) more than the next lowest bidder, to ensure that a preference is given to local contractors and vendors.
- (b) A preference maybe given to the lowest bidder who in good faith:
 - (1) Holds a current Florida business license; and
 - (2) Submits a bid under the name of said Florida business license; and
 - (3) Has maintained a place of business within Bradford County, staffed by the bidder or an employee of the bidder, for a period not less than one year immediately preceding the date of the bid; and
 - (4) Is incorporated under Florida law, or is a sole proprietorship whose proprietor is a resident of the county, or is a partnership, at least one of whose partners are residents of the county; or
 - (5) Is a joint venture, all of whose ventures qualify under the relevant portion of subsection (b)(4) above; or
 - (6) Is a limited liability company whose manager is a resident of Bradford County.

- (c) Establishment of a temporary or satellite office or securing a mail receptacle within the county shall not constitute "residence" for the purpose of this section.
- (d) No preference will be given to a bidder who, in the sole discretion of the county, has created, setup, changed, altered or amended the form of its business operation so as to meet the criteria to become a "preferred bidder" as outlined herein.
- (e) A bidder, if any, meeting the above criteria is referred to as the "preferred bidder." If a preferred bidder submits a bid proposal which is not the lowest bid, the preferred bidder may be entitled to match the lowest bid and be considered the lowest, best bidder by providing written notice to the county immediately after the bid tabulation.
- (f) If more than one "preferred bidder" seeks to match the original low bidder, the bid and related contract shall be awarded to the preferred bidder whose original bid was the best low bid of the "preferred bidder."
- (g) Any "preferred bidder" shall certify in writing to Bradford County that it will make its best effort to employ as many local subcontractors, suppliers, material, men and employees as is possible for the job for which they submitted their proposal.

Sec. 2-157. - Competitive sealed bidding.

- (a) Required. All contracts for purchases in excess of \$25,000.00 shall be awarded by the county commission on the basis of sealed competitive bids.
- (b) Invitation to bid; generally. Public notice of an invitation to bid shall provide a reasonable time prior to the date set for the opening of bids. Such notice shall involve publication in a newspaper of general circulation or appropriate trade journal for a reasonable time period prior to bid opening.
- (c) Opening bids. Bids shall be opened publicly in the presence of the clerk or his designee, the county manager or his designee, and one or more witnesses at the time and place designated in the invitation to bid. The amount of each bid and such other relevant information as may be specified by policy or specification, together with the name of each bidder, shall be recorded. The record of each bid shall be open to public inspection.
- (d) Evaluation of bids. Bids shall be unconditionally accepted without alteration or correction, except as authorized by this article. Bids shall be evaluated based on the requirements set forth in the invitation to bid, which may involve criteria to determine acceptability such as inspection, testing, quality, workmanship, delivery, and suitability for a particular purpose. Criteria which may affect the bid price may be considered in evaluation for the award if the criteria can be objectively measured, such as discounts, transportation costs, and total or life cycle costs.
- (e) Bid changes, withdrawal, etc. Correction or withdrawal of inadvertently erroneous bids before or after award, or cancellation of awards or contracts based on such bid mistakes, shall be permitted in accordance with policies or regulations promulgated by the board of county commissioners. After bid opening, no changes shall be permitted in bid price or other provisions or

bids prejudicial to the interest of the county or fair competition. In implementing this requirement, the county manager shall be guided by the standards set forth in section 3-202(6) of the Florida Model Procurement Code. Except as otherwise provided by policy or regulation, all decisions to permit the correction or withdrawal of bids or to cancel awards or contracts based on bid mistakes shall be made within five days after bid opening and shall be supported by a written determination made by the county manager and approved by the board of county commissioners.

- (f) Award of contract. A bid report, in the case where bids contain a price greater than \$25,000.00, shall be presented to the board of county commissioners for final approval. Following final approval by the board of county commissioners, the contract shall be awarded with reasonable promptness. Contracts awarded by the board of county commissioners shall be awarded to the lowest responsible and responsive bidder whose bid meets the requirements and criteria set forth in the invitation to bid.
- (g) Approval of change orders. In the case of capital improvement projects where there is a change order, the following procedure shall apply:
 - (1) All change orders require approval by the board of county commissioners and shall be presented to them for such approval as soon as is reasonably possible following receipt thereof;
 - (2) In the event of an emergency or when circumstances otherwise require, the county manager or his designee is authorized to approve change orders pursuant to the requirements of section 2-162 herein.
 - (3) Notwithstanding the requirement of section 2-157(g)(1) above, change orders for projects managed by the community development department, which would ordinarily require the approval of the board of county commissioners, for amounts valued at \$500.00 or less, maybe approved by the county manager or his designee without the necessity of approval by the board of county commissioners.
- (h) The board of county commissioners hereby specifically adopts and incorporates in their entirety the provisions of 2 Code of Federal Regulations (CFR) section 200, specifically including subsections 318 through 326, as follows and as may be amended from time to time:

§ 200.318 General procurement standards.

- (a) The non-Federal entity must use its own documented procurement procedures which reflect applicable State, local, and tribal laws and regulations, provided that the procurements conform to applicable Federal law and the standards identified in this part.
- (b) Non-Federal entities must maintain oversight to ensure that contractors perform in accordance with the terms, conditions, and specifications of their contracts or purchase orders.
- (c)
 - (1) The non-Federal entity must maintain written standards of conduct covering conflicts of interest and governing the actions

of its employees engaged in the selection, award and administration of contracts. No employee, officer, or agent may participate in the selection, award, or administration of a contract supported by a Federal award if he or she has a real or apparent conflict of interest. Such a conflict of interest would arise when the employee, officer, or agent, any member of his or her immediate family, his or her partner, or an organization which employs or is about to employ any of the parties indicated herein, has a financial or other interest in or a tangible personal benefit from a firm considered for a contract. The officers, employees, and agents of the non-Federal entity may neither solicit nor accept gratuities, favors, or anything of monetary value from contractors or parties to subcontracts. However, non-Federal entities may set standards for situations in which the financial interest is not substantial or the gift is an unsolicited item of nominal value. The standards of conduct must provide for disciplinary actions to be applied for violations of such standards by officers, employees, or agents of the non-Federal entity.

- (2) If the non-Federal entity has a parent, affiliate, or subsidiary organization that is not a state, local government, or Indian tribe, the non-Federal entity must also maintain written standards of conduct covering organizational conflicts of interest. Organizational conflicts of interest means that because of relationships with a parent company, affiliate, or subsidiary organization, the non-Federal entity is unable or appears to be unable to be impartial in conducting a procurement action involving a related organization.
- (d) The non-Federal entity's procedures must avoid acquisition of unnecessary or duplicative items. Consideration should be given to consolidating or breaking out procurements to obtain a more economical purchase. Where appropriate, an analysis will be made of lease versus purchase alternatives, and any other appropriate analysis to determine the most economical approach.
- (e) To foster greater economy and efficiency, and in accordance with efforts to promote cost-effective use of shared services across the Federal government, the non-Federal entity is encouraged to enter into State and local intergovernmental agreements or inter-entity agreements where appropriate for procurement or use of common or shared goods and services.
- (f) The non-Federal entity is encouraged to use Federal excess and surplus property in lieu of purchasing new equipment and property whenever such use is feasible and reduces project costs.
- (g) The non-Federal entity is encouraged to use value engineering clauses in contracts for construction projects of sufficient size to offer reasonable opportunities for cost reductions. Value engineering is a

systematic and creative analysis of each contract item or task to ensure that its essential function is provided at the overall lower cost.

- (h) The non-Federal entity must award contracts only to responsible contractors possessing the ability to perform successfully under the terms and conditions of a proposed procurement. Consideration will be given to such matters as contractor integrity, compliance with public policy, record of past performance, and financial and technical resources.

See also § 200.213 Suspension and debarment.

- (i) The non-Federal entity must maintain records sufficient to detail the history of procurement. These records will include, but are not necessarily limited to the following: rationale for the method of procurement, selection of contract type, contractor selection or rejection, and the basis for the contract price.

- (j)
 - (1) The non-Federal entity may use a time and materials type contract only after a determination that no other contract is suitable and if the contract includes a ceiling price that the contractor exceeds at its own risk. Time and materials type contract means a contract whose cost to a non-Federal entity is the sum of:

- (i) The actual cost of materials; and
 - (ii) Direct labor hours charged at fixed hourly rates that reflect wages, general and administrative expenses, and profit.

- (2) Since this formula generates an open-ended contract price, a time-and-materials contract provides no positive profit incentive to the contractor for cost control or labor efficiency. Therefore, each contract must set a ceiling price that the contractor exceeds at its own risk. Further, the non-Federal entity awarding such a contract must assert a high degree of oversight in order to obtain reasonable assurance that the contractor is using efficient methods and effective cost controls.

- (k) The non-Federal entity alone must be responsible, in accordance with good administrative practice and sound business judgment, for the settlement of all contractual and administrative issues arising out of procurements. These issues include, but are not limited to, source evaluation, protests, disputes, and claims. These standards do not relieve the non-Federal entity of any contractual responsibilities under its contracts. The Federal awarding agency will not substitute its judgment for that of the non-Federal entity unless the matter is primarily a Federal concern. Violations of law will be referred to the local, State, or Federal authority having proper jurisdiction.

§ 200.319 Competition.

- (a) All procurement transactions must be conducted in a manner providing full and open competition consistent with the standards of this section. In order to ensure objective contractor performance and eliminate unfair competitive advantage, contractors that develop or draft specifications, requirements, Statements of work, or invitations for bids or requests for proposals must be excluded from competing for such procurements. Some of the situations considered to be restrictive of competition include but are not limited to:
 - (1) Placing unreasonable requirements on firms in order for them to qualify to do business;
 - (2) Requiring unnecessary experience and excessive bonding;
 - (3) Noncompetitive pricing practices between firms or between affiliated companies;
 - (4) Noncompetitive contracts to consultants that are on retainer contracts;
 - (5) Organizational conflicts of interest;
 - (6) Specifying only a "brand name" product instead of allowing "an equal" product to be offered and describing the performance or other relevant requirements of the procurement; and
 - (7) Any arbitrary action in the procurement process.
- (b) The non-Federal entity must conduct procurements in a manner that prohibits the use of statutorily or administratively imposed state, local, or tribal geographical preferences in the evaluation of bids or proposals, except in those cases where applicable Federal statutes expressly mandate or encourage geographic preference. Nothing in this section preempts State licensing laws. When contracting for architectural and engineering (A/E) services, geographic location may be a selection criterion provided its application leaves an appropriate number of qualified firms, given the nature and size of the project, to compete for the contract.
- (c) The non-Federal entity must have written procedures for procurement transactions. These procedures must ensure that all solicitations:
 - (1) Incorporate a clear and accurate description of the technical requirements for the material, product, or service to be procured. Such description must not, in competitive procurements, contain features which unduly restrict competition. The description may include a statement of the qualitative nature of the material, product or service to be procured and, when necessary, must set forth those minimum essential characteristics and standards to which it must conform if it is to satisfy its intended use. Detailed product specifications should be avoided if at all possible. When it is impractical or uneconomical to make a clear and accurate description of the technical requirements, a "brand name or equivalent" description may be used as a means to define the performance or other salient requirements of procurement. The

specific features of the named brand which must be met by offers must be clearly stated; and

- (2) Identify all requirements which the offerors must fulfill and all other factors to be used in evaluating bids or proposals.
- (d) The non-Federal entity must ensure that all prequalified lists of persons, firms, or products which are used in acquiring goods and services are current and include enough qualified sources to ensure maximum open and free competition. Also, the non-Federal entity must not preclude potential bidders from qualifying during the solicitation period.

§ 200.320 Methods of procurement to be followed.

The non-Federal entity must use one of the following methods of procurement.

- (a) Procurement by micro-purchases. Procurement by micro-purchase is the acquisition of supplies or services, the aggregate dollar amount of which does not exceed the micro-purchase threshold (§ 200.67 Micro-purchase). To the extent practicable, the non-Federal entity must distribute micro-purchases equitably among qualified suppliers. Micro-purchases may be awarded without soliciting competitive quotations if the non-Federal entity considers the price to be reasonable.
- (b) Procurement by small purchase procedures. Small purchase procedures are those relatively simple and informal procurement methods for securing services, supplies, or other property that do not cost more than the Simplified Acquisition Threshold. If small purchase procedures are used, price or rate quotations must be obtained from an adequate number of qualified sources.
- (c) Procurement by sealed bids (formal advertising). Bids are publicly solicited and a firm fixed price contract (lump sum or unit price) is awarded to the responsible bidder whose bid, conforming with all the material terms and conditions of the invitation for bids, is the lowest in price. The sealed bid method is the preferred method for procuring construction, if the conditions in paragraph (c)(1) of this section apply.
 - (1) In order for sealed bidding to be feasible, the following conditions should be present:
 - (i) A complete, adequate, and realistic specification or purchase description is available;
 - (ii) Two or more responsible bidders are willing and able to compete effectively for the business; and
 - (iii) The procurement lends itself to a firm fixed price contract and the selection of the successful bidder can be made principally on the basis of price.
 - (2) If sealed bids are used, the following requirements apply:
 - (i) Bids must be solicited from an adequate number of known suppliers, providing them sufficient response time prior to the

- date set for opening the bids, for local, and tribal governments, the invitation for bids must be publicly advertised;
- (ii) The invitation for bids, which will include any specifications and pertinent attachments, must define the items or services in order for the bidder to properly respond;
 - (iii) All bids will be opened at the time and place prescribed in the invitation for bids, and for local and tribal governments, the bids must be opened publicly;
 - (iv) A firm fixed price contract award will be made in writing to the lowest responsive and responsible bidder. Where specified in bidding documents, factors such as discounts, transportation cost, and life cycle costs must be considered in determining which bid is lowest. Payment discounts will only be used to determine the low bid when prior experience indicates that such discounts are usually taken advantage of; and
 - (v) Any or all bids may be rejected if there is a sound documented reason.
- (d) Procurement by competitive proposals. The technique of competitive proposals is normally conducted with more than one source submitting an offer, and either a fixed price or cost-reimbursement type contract is awarded. It is generally used when conditions are not appropriate for the use of sealed bids. If this method is used, the following requirements apply:
- (1) Requests for proposals must be publicized and identify all evaluation factors and their relative importance. Any response to publicized requests for proposals must be considered to the maximum extent practical;
 - (2) Proposals must be solicited from an adequate number of qualified sources;
 - (3) The non-Federal entity must have a written method for conducting technical evaluations of the proposals received and for selecting recipients;
 - (4) Contracts must be awarded to the responsible firm whose proposal is most advantageous to the program, with price and other factors considered; and
 - (5) The non-Federal entity may use competitive proposal procedures for qualifications-based procurement of architectural/engineering (A/E) professional services whereby competitors' qualifications are evaluated and the most qualified competitor is selected, subject to negotiation of fair and reasonable compensation. The method, where price is not used as a selection factor, can only be used in procurement of A/E professional services. It cannot be used to purchase other types of services though A/E firms are a potential source to perform the proposed effort.
- (e) [Reserved]

- (f) Procurement by noncompetitive proposals. Procurement by noncompetitive proposals is procurement through solicitation of a proposal from only one source and may be used only when one or more of the following circumstances apply:
- (1) The item is available only from a single source;
 - (2) The public exigency or emergency for the requirement will not permit a delay resulting from competitive solicitation;
 - (3) The Federal awarding agency or pass-through entity expressly authorizes noncompetitive proposals in response to a written request from the non-Federal entity; or
 - (4) After solicitation of a number of sources, competition is determined inadequate.

§ 200.321 Contracting with small and minority businesses, women's business enterprises, and labor surplus area firms.

- (a) The non-Federal entity must take all necessary affirmative steps to assure that minority businesses, women's business enterprises, and labor surplus area firms are used when possible.
- (b) Affirmative steps must include:
- (1) Placing qualified small and minority businesses and women's business enterprises on solicitation lists;
 - (2) Assuring that small and minority businesses, and women's business enterprises are solicited whenever they are potential sources;
 - (3) Dividing total requirements, when economically feasible, into smaller tasks or quantities to permit maximum participation by small and minority businesses, and women's business enterprises;
 - (4) Establishing delivery schedules, where the requirement permits, which encourage participation by small and minority businesses, and women's business enterprises;
 - (5) Using the services and assistance, as appropriate, of such organizations as the Small business administration and the minority business development agency of the department of commerce; and
 - (6) Requiring the prime contractor, if subcontracts are to be let, to take the affirmative steps listed in paragraphs (1) through (5) of this section.

§ 200.322 Procurement of recovered materials.

A non-Federal entity that is a State agency or agency of a political subdivision of a state and its contractors must comply with section 6002 of the Solid Waste Disposal Act, as amended by the Resource Conservation and Recovery Act. The requirements of Section 6002 include procuring only items designated in guidelines of the environmental protection agency (EPA) at 40 CFR part 247 that contain the highest percentage of recovered materials practicable, consistent with maintaining

a satisfactory level of competition, where the purchase price of the item exceeds \$10,000 or the value of the quantity acquired during the preceding fiscal year exceeded \$10,000; procuring solid waste management services in a manner that maximizes energy and resource recovery; and establishing an affirmative procurement program for procurement of recovered materials identified in the EPA guidelines.

§ 200.323 Contract cost and price.

- (a) The non-Federal entity must perform a cost or price analysis in connection with every procurement action in excess of the Simplified Acquisition Threshold including contract modifications. The method and degree of analysis is dependent on the facts surrounding the particular procurement situation, but as a starting point, the non-Federal entity must make independent estimates before receiving bids or proposals.
- (b) The non-Federal entity must negotiate profit as a separate element of the price for each contract in which there is no price competition and in all cases where cost analysis is performed. To establish a fair and reasonable profit, consideration must be given to the complexity of the work to be performed, the risk borne by the contractor, the contractor's investment, the amount of subcontracting, the quality of its record of past performance, and industry profit rates in the surrounding geographical area for similar work.
- (c) Costs or prices based on estimated costs for contracts under the Federal award are allowable only to the extent that costs incurred or cost estimates included in negotiated prices would be allowable for the non-Federal entity under Subpart E—Cost Principles of this part. The non-Federal entity may reference its own cost principles that comply with the Federal cost principles.
- (d) The cost plus a percentage of cost and percentage of construction cost methods of contracting must not be used.

§ 200.324 Federal awarding agency or pass-through entity review.

- (a) The non-Federal entity must make available, upon request of the Federal awarding agency or pass-through entity, technical specifications on proposed procurements where the Federal awarding agency or pass-through entity believes such review is needed to ensure that the item or service specified is the one being proposed for acquisition. This review generally will take place prior to the time the specification is incorporated into a solicitation document. However, if the non-Federal entity desires to have the review accomplished after a solicitation has been developed, the Federal awarding agency or pass-through entity may still review the specifications, with such review usually limited to the technical aspects of the proposed purchase.
- (b) The non-Federal entity must make available upon request, for the Federal awarding agency or pass-through entity pre-procurement review,

procurement documents, such as requests for proposals or invitations for bids, or independent cost estimates, when:

- (1) The non-Federal entity's procurement procedures or operation fails to comply with the procurement standards in this part;
 - (2) The procurement is expected to exceed the Simplified Acquisition Threshold and is to be awarded without competition or only one bid or offer is received in response to a solicitation;
 - (3) The procurement, which is expected to exceed the Simplified Acquisition Threshold, specifies a "brand name" product;
 - (4) The proposed contract is more than the Simplified Acquisition Threshold and is to be awarded to other than the apparent low bidder under a sealed bid procurement; or
 - (5) A proposed contract modification changes the scope of a contract or increases the contract amount by more than the Simplified Acquisition Threshold.
- (c) The non-Federal entity is exempt from the pre-procurement review in paragraph (b) of this section if the Federal awarding agency or pass-through entity determines that its procurement systems comply with the standards of this part.
- (1) The non-Federal entity may request that its procurement system be reviewed by the Federal awarding agency or pass-through entity to determine whether its system meets these standards in order for its system to be certified. Generally, these reviews must occur where there is continuous high-dollar funding, and third party contracts are awarded on a regular basis;
 - (2) The non-Federal entity may self-certify its procurement system. Such self-certification must not limit the Federal awarding agency's right to survey the system. Under a self-certification procedure, the Federal awarding agency may rely on written assurances from the non-Federal entity that it is complying with these standards. The non-Federal entity must cite specific policies, procedures, regulations, or standards as being in compliance with these requirements and have its system available for review.

§ 200.325 Bonding requirements.

For construction or facility improvement contracts or subcontracts exceeding the Simplified Acquisition Threshold, the Federal awarding agency or pass-through entity may accept the bonding policy and requirements of the non-Federal entity provided that the Federal awarding agency or pass-through entity has made a determination that the Federal interest is adequately protected. If such a determination has not been made, the minimum requirements must be as follows:

- (a) A bid guarantee from each bidder equivalent to five percent of the bid price. The "bid guarantee" must consist of a firm commitment such as a bid bond, certified check, or other negotiable instrument accompanying a bid as

assurance that the bidder will, upon acceptance of the bid, execute such contractual documents as may be required within the time specified.

- (b) A performance bond on the part of the contractor for 100 percent of the contract price. A “performance bond” is one executed in connection with a contract to secure fulfillment of all the contractor's obligations under such contract.
- (c) A payment bond on the part of the contractor for 100 percent of the contract price. A “payment bond” is one executed in connection with a contract to assure payment as required by law of all persons supplying labor and material in the execution of the work provided for in the contract.

§ 200.326 Contract provisions.

The non-Federal entity's contracts must contain the applicable provisions described in appendix II to Part 200—Contract Provisions for Non-Federal Entity Contracts Under Federal Awards.

Sec. 2-158. - Informal bids.

The following procedures shall govern all budgeted purchases up to and including \$25,000.00, provided that there are budgeted funds available to fund the purchase or contract:

- (1) In the case of purchases of a value not greater than \$1,000.00 the county manager, their designee(s), or the department head as his designee(s) are authorized to make such purchases
- (2) In the case of purchases of a value greater than \$1,000.00, but less than \$5,000.00, the county manager, his designee(s), or the department head as his designee, are authorized to make such purchases, based on three telephone quotations and with county manager approval.
- (3) In the case of purchases of a value greater than \$5,000.00, but not more than \$25,000.00, the county manager, his designee(s) or department head is authorized to make such purchases on the basis of three written quotations or current state contract and with county manager approval.
- (4) In the case of purchases of a value greater than \$25,000.00, such purchases shall be awarded by competitive bid and following approval by the board of county commissioners;
- (5) Notwithstanding any other provision of this section, in the event that the county manager or his designee determines that the requisite number of quotations are not reasonably available given the facts and circumstances presented at that time, they may deviate from said requirement.

Sec. 2-159. - Exemption from bidding process.

- (a) The following purchases and contracts shall be exempt from the county competitive bid process:

- (1) All purchases of services from a utility whose rates are determined and controlled by the public service commission of the State or other governmental authority;
- (2) All supplies, materials, equipment, or services purchased at a price established by the State purchasing agency, or at a price equal to or less than the price established by the State purchasing agency;
- (3) All supplies, materials, equipment, or services purchased at a price equal to or less than the price established by another State agency, county, or quasi-governmental agency as the lowest responsible bid price; providing that such low bid price was obtained not more than 180 days before the contract awarded by the county;
- (4) All supplies, materials, equipment, construction, or services purchased from another unit of government;
- (5) Sole source purchases as provided in section 2-160;
- (6) Emergency purchases as provided in section 2-161;
- (7) Emergency projects and engagements as provided in section 2-162;
- (8) All purchases of perishable items such as fresh vegetables, fruit, fish, meat, eggs, and milk;
- (9) All purchases of real property having a value of \$20,000.00 or less; however, each such purchase shall be supported by an opinion of value by the county property appraiser;
- (10) All purchases of real property having a value of \$20,000.00 and up to and including \$500,000.00; however, each such purchase shall be supported by an independent appraisal report prepared by an MAI appraiser and an opinion of value by the county property appraiser;
- (11) All purchases of real property having a value greater than \$500,000.00; however, each such purchase shall be supported by two independent appraisal reports prepared by different MAI appraisers within eight months of the proposed purchase;
- (12) All purchases of used equipment, provided that each such purchase shall either be supported by one independent equipment appraisal report, or specifically approved by the board of county commissioners;
- (13) Supplies, materials, or services purchased under an annual or other time contract awarded by the board of county commissioners;
- (14) Services of a professional nature, including engineering, architectural, land surveying, and landscape architectural services which are controlled by F.S. § 287.055, and medical and legal services. Other services of a professional nature whose estimated cost does not exceed \$25,000.00 are also exempt;
- (15) Supplies, materials, and equipment purchased through construction management services directly from vendors identified as part of the bid of a contractor or subcontractor who had been awarded work as part of the construction management project; and
- (16) Purchases of supplies, materials, equipment and services under contract obtained by Federal, State, or municipal governments or any

other governmental agency or political subdivision, provided that the vendor extends the same terms and conditions of the contract to the county, based on the determination by the board of county commissioners that of such purchases are in the best interest of the county.

Sec. 2-160. - Sole source purchase.

- (a) A contract may be awarded for a supply, service, material, equipment, or construction item without competition when:
 - (1) The county manager certifies that there is only one reasonable and/or feasible source for the required material, supply, service, equipment, or construction item; or
 - (2) When over \$25,000.00, such contracts shall not be awarded until they have been approved by the board of county commissioners; or
 - (3) On occasions when obtaining a supply, service, material, equipment, or construction item from a specific source would provide a significant benefit to Bradford County, as determined by the county manager or his designee.
- (b) All final approvals of sole source certifications shall be made at the discretion of the board of county commissioners and their approval shall be considered final.

Sec. 2-161. - Emergency purchases.

Notwithstanding any other provision of this article, the county manager or a department head may make or authorize others to make emergency purchases when there exists a threat to public health, welfare, or safety under emergency conditions. The following procedures shall govern:

- (1) The department head shall contact the county manager and relate the emergency condition;
- (2) The county manager, or his designee, shall obtain the best possible purchase price for the item or service to be purchased by the quickest possible means; ~~and where feasible, an attempt shall be made to obtain three telephone quotes;~~
- (3) When the emergency occurs after normal working hours, on weekends, or holidays, and any delay would be detrimental to the county, the department head shall initiate the emergency purchase and shall notify the county manager by 5:00 p.m. on the next work day.
- (4) When possible, all emergency purchases shall be accompanied by a written determination of the basis for the emergency which shall be signed by the department head and county manager or his designee.
- ~~(5) A purchase order should be obtained as soon as is practicable following any emergency purchase made pursuant to this section.~~

Sec. 2-162. - Emergency projects and engagements.

- (a) In the event of an emergency, the county manager is authorized to engage services and/or make purchases in excess of the price and/or cost limits provided for elsewhere herein.
- (b) Any emergency engagement or purchase shall be made by the county manager only after making a reasonable and diligent attempt to advise the clerk to the board and to obtain the consent of the chairman of the board of county commissioners.
- (c) All emergency engagements and/or purchases shall be presented to the board of county commissioners for their approval at the regularly scheduled meeting immediately following the engagement and/or purchase.

Sec. 2-163. - Contract crime and revocation of bid qualification.

- (a) Definitions. The following words and phrases, when used in this section, have the following meanings:
 - (1) Affiliate means a predecessor or successor of a contractor under the same, or substantially the same, control, or a group of business entities which are connected or associated so that one entity controls or has the power to control each of the other business entities. The term "affiliate" includes the officers, directors, executives, shareholders active in management, employees, and agents of the affiliate. The ownership by one business entity or a pooling of equipment or income among business entities shall be prima facie evidence that one business entity is an affiliate of another;
 - (2) Contract crime means any violation of state or Federal antitrust laws with respect to a public contract or any violation or any state or Federal law involving fraud, bribery, collusion, conspiracy, or material misrepresentation with respect to a public contract;
 - (3) Contractor means any person who bids or applies to bid on purchasing activity which is subject to this article or who provides professional services to the county. The term "contractor" includes the officers, directors, executives, shareholders active in management, employees, and agents of the contractor;
 - (4) Convicted or conviction means a finding of guilt or a conviction of a contract crime, with or without an adjudication of guilt, in any Federal or state court as a result of a jury verdict, non-jury trial, or entry of a plea of nolo contendere or plea of guilty;
 - (5) Pooling means a combination of persons or corporations engaged in the same business, or for the purpose of engaging in a particular business or commercial or speculative venture in which all contribute to a common

fund or place their holding of a given stock or other security in the hands and control of a managing member or committee.

(b) Prohibition, hearing, reapplication, or reinstatement.

- (1) No contractor or contractor affiliate shall be qualified to bid on purchases being made by the county when it is determined upon information provided to the county manager that such contractor or contractor affiliate has been convicted of a contract crime within the jurisdiction of any state or Federal court.
- (2) When the county manager receives notice that a contractor has been convicted of a contract crime, the county manager shall inform the contractor or contractor affiliate in writing of his intent to end or revoke the contractor's or affiliate's qualification to bid on purchases by the county. A contractor or affiliate wishing to appeal such a decision must request a hearing in writing within ten days of receipt of the notice of intent. The county manager shall then notify the contractor or affiliate of the time, date, and place of the hearing, which shall be held within 30 days of receipt of the request for hearing. If the county manager determines that the contractor or contractor affiliate has been convicted of a contract crime, the county manager shall deny or revoke the contractor's or contractor affiliate's qualification to bid on county purchases for a period of 24 months.
- (3) Any person who is notified by the county manager of his intent to deny or revoke qualification to bid on any purchases to be made by the county because of such person's status as an affiliate or a contractor convicted of a contract crime may, at the hearing provided for herein, offer proof that such person is not an affiliate as defined herein. The submission of an affidavit alone shall not constitute competent, substantial evidence that the person is not an affiliate. If the county manager finds that such person is not an affiliate, then such person's qualification to bid on purchases to be made by the county may not be denied or revoked.
- (4) A contractor or affiliate whose qualification to bid on county purchasing activities has been denied or revoked because of a conviction of a contract crime and who is subsequently convicted of a contract crime committed within ten years of such denial or revocation may not be considered for eligibility pursuant to subsection (b)(5) below until 24 months after the date of the denial or revocation based upon such subsequent conviction. A contractor or affiliate whose qualification to bid on county purchases has been denied or revoked may, at any time after denial or revocation, petition for and be granted a hearing to determine the contractor's or affiliate's eligibility for reapplication or reinstatement upon such terms and conditions as may be prescribed upon finding that reapplication or reinstatement is in the public interest. Any hearing conducted by the county manager shall be conducted within 30 days after receipt of the petition. In determining whether reapplication or reinstatement would be in the public interest, the county

manager shall give consideration to any relevant mitigating circumstances, which may include, but are not limited to, the following:

- a. The degree of culpability;
 - b. Prompt and voluntary payment of damages resulting from the violation of state or Federal antitrust laws;
 - c. Cooperation with any state or Federal prosecution or investigation of a contract crime;
 - d. Disassociation with those involved in a contract crime;
 - e. Reinstatement in other state or Federal jurisdictions; and
 - f. The needs of the county in completing its program in a timely, cost effective manner.
- (5) The hearing provided for in this section shall be conducted without undue delay and the county manager shall, within 30 days of such hearing, prepare a written order indicating whether the petition is granted or denied. A petitioner whose petition for reapplication or reinstatement is denied, may not petition for subsequent hearing for a period of 12 months following the date of the order of denial.
- (c) [Prohibited activities.] A contractor or affiliate whose qualification to bid on county purchases is denied or revoked pursuant to this section may not act as a prime contractor, subcontractor, material supplier, or consultant on any county purchases during the period of such denial or revocation.
- (d) [Obligations under pre-existing contract.] The denial or revocation of a contractor's or affiliate's qualification shall not affect the contractor's or affiliate's obligations under any pre-existing contract.
- (e) [Notification of conviction.] A contractor or affiliate who is currently qualified to bid on county purchases or is seeking to be qualified shall notify the county manager within 30 days after conviction of a contract crime applicable to such contractor or to any affiliate or to any such contractor's or affiliate's officers, directors, executives, shareholders active in management, employees or agents.
- (f) [Bids in excess of \$35,000.] As provided for in F.S. § 287.017, on all bids in excess of \$35,000.00 vendors are required to submit a sworn statement to the county certifying that neither the bidder or contractor nor anyone active in the management of the bidder or contractor has been convicted of a public entity crime subsequent to July 1, 1989.

Sec. 2-164. - Competitive sealed proposals.

- (a) When the county manager or board of county commissioners determines that the use of competitive sealed bids are either not practical or not advantageous to the county, a contract for material, supplies, services, construction, and equipment may be entered into by the use of competitive sealed proposals. Some of the situations where this method may be utilized include, but are not limited to, the following:
- (1) When fixed price or cost type contracts are not appropriate;

- (2) When quality, availability, or capability is overriding in relation to price in procurement of services, technical goods, research and development, or testing services;
 - (3) When the initial installation needs to be evaluated, together with subsequent maintenance and service capabilities and when priority should be given these requirements in terms of the best interest of the county;
 - (4) When the market place will respond favorably to a solicitation permitting not only a range of alternate proposals but also permitting evaluation and discussion by the county with responders before making the award;
 - (5) When a performance specification is deemed more appropriate than a technical specification or price.
- (b) Adequate public notice of the request for proposals shall be given in the same manner as for competitive bidding.
 - (c) The request for proposals shall state the relative importance of price and other evaluation factors.
 - (d) As provided in the request for proposals, and under regulations promulgated by the board of county commissioners, discussions may be conducted with responsible offerors who submit proposals determined to be reasonably susceptible of being selected for award. The purpose of clarification discussions is to assure full understanding of, and responsiveness to, the solicitation requirements. Offerors shall be accorded fair and equal treatment with respect to any opportunity for discussion and revision of proposals, and such revisions may be permitted after submissions and prior to award for the purpose of obtaining best and final offers. In conducting discussions there shall be no disclosure of any information derived from proposals submitted by competing offerors.
 - (e) The award shall be made to the responsible offeror whose proposal is determined to be the most advantageous to the county, taking into consideration price (where applicable) and the evaluation factors set forth in the request for proposals.

Sec. 2-165. - Cancellation of bids.

An invitation to bid, a request for proposals, or any other solicitation may be canceled, or any or all bids or proposals may be rejected in whole or part regardless of whether specified in the solicitation, when it is determined by the board of county commissioners to be in the best interest of the county. The substance of this section shall be restated in all invitations to bid and request for proposals.

Sec. 2-166. - Specifications.

- (a) The county manager shall promulgate and amend as necessary regulations governing the preparation, maintenance, and control of specifications for

materials, supplies, services, construction, and equipment to be purchased by the county.

- (b) The county manager shall prepare, issue, revise, maintain, and monitor the use of specifications for materials, supplies, services, construction, and equipment required by the county.
- (c) All specifications shall seek to promote overall economy for the purposes intended and encourage competition without being unduly restrictive.
- (d) The requirements of this section regarding the purposes and non-restrictiveness of specifications shall apply to all specifications, including, but not limited to, those prepared by architects, engineers, designers, draftsmen, and others retained or working for and on behalf of the county.

Sec. 2-167. - Complaints or grievances.

All vendor complaints or grievances shall first be submitted in writing to the county manager within five days of the vendor becoming aware of the complaint or situation. The county manager shall investigate the validity of the complaint and present his or her findings in writing to the vendor within five days. If the vendor is dissatisfied with the county manager's findings or remedies, he or she may file a written appeal with the board of county commissioners within three days of the vendor's receipt of the county manager's decision. The board of county commissioners will then hear the complaint or grievance at its next regularly scheduled meeting and shall render a decision on the complaint or grievance. All decisions by the board of county commissioners shall be considered final, and no further appeal shall be allowed.

Sec. 2-168. - Bid protests and appeals.

- (a) Any person who is directly and substantially affected by the county's decision or intended decision to award a contract or other purchase order shall file with the board of county commissioners a notice of protest in writing within 72 hours after the posting of the bid tabulation or after receipt of the notice of the county's award decision or intended award decision and shall then file a formal written protest within ten days after filing the notice of protest. With respect to a protest of the specifications contained in an invitation to bid or in a request for proposals, the notice of protest shall be filed in writing within 72 hours after the receipt of notice of the project plans and specifications or intended project plans and specifications in an invitation to bid or request for proposals, and the formal written protest shall be filed within ten days after the date of the notice of protest is filed. Failure to file a notice of protest or failure to file a formal written protest shall constitute a waiver of proceedings under this article and state statutes. Any formal written protest shall state with particularity the facts and law upon which the protest is based.
- (b) Upon receipt of any formal written protest which has been timely filed, the board of county commissioners shall stop the bid solicitation process or the

contract award process until the subject of the protest is resolved by final commission action, unless the chairman of the board of county commissioners sets forth in writing, with particularity, facts and circumstances which require the continuance of the bid solicitation process or the contract award process without delay in order to avoid immediate and severe damage to the public health, safety or welfare.

- (c) The board of county commissioners shall provide an opportunity to resolve any protest by mutual agreement between the parties within seven days, excluding Saturdays, Sundays, and legal holidays, after the receipt of a formal written protest.
- (d) If the written protest cannot be resolved by mutual agreement between the parties, the protest shall be referred for hearing before an administrative hearing officer. All such hearings shall be conducted in accordance with the provisions of F.S. § 120.57.

Sec. 2-169. - Construction of provisions.

The provisions of this article shall be liberally construed in order to effectively carry out its purposes which are deemed to be in the best interest of the public health, safety and welfare of the county's citizens and residents.

Sec. 2-170. - Purchase order rules.

The county manager and the clerk to the board shall prepare formal written procedures and forms to necessitate the implementation of the requirements of this article.

Sec. 2-171. - Penalties for violations.

Any violation of the purchasing or bidding procedures established by this article or by the written procedures adopted pursuant hereto by a county employee shall subject the employee to disciplinary action, including possible termination.

Sec. 2-172. - Federal grant awards.

The Board of County Commissioners of Bradford County, Florida will adhere to all federal purchasing requirements in the administration of federal grant awards.

- 3. SEVERABILITY.** If any section, subsection or provision of this resolution, or its application to any person or circumstance, is for any reason held to be invalid or unenforceable, such invalidity or unenforceability shall not affect the validity or enforceability of the remaining sections or provisions of this ordinance or its application to any other person or circumstance.
- 4. DIRECTION TO CODIFIER.** It is the intention of the Board of County Commissioners of Bradford County, Florida that this ordinance shall become and be

made a part of the Bradford County Code, and that when codified; the sections and paragraphs of this ordinance may be renumbered or re-lettered to accomplish such intention.

- 5. EFFECTIVE DATE.** The resolution shall take effect upon adoption by the Bradford County Board of County Commissioners.

PASSED AND ADOPTED in regular session of the Board of County Commissioners, with a quorum present this _____ day of April 2026.

**BOARD OF COUNTY COMMISSIONERS
BRADFORD COUNTY, FLORIDA.**

By: _____
Carolyn Spooner, Chair

ATTEST:

Denny Thompson, Clerk of Court

NOTICE OF ENACTMENT OF ORDINANCES BY THE BOARD OF COUNTY COMMISSIONERS OF BRADFORD COUNTY, FLORIDA

NOTICE IS HEREBY GIVEN that the ordinances, which titles hereinafter appear, will be considered for enactment by the Board of County Commissioners of Bradford County, Florida, at a public hearing on April 7, 2026, at 9:30 AM, or as soon thereafter as the matters can be heard, in the County Commission Meeting Room, North Wing, County Courthouse located at 945 North Temple Avenue, Starke, Florida. The ordinance will be considered for final enactment by the Board of County Commissioners of Bradford County, Florida on April 16, 2026, at 6:30 PM, or as soon thereafter as the matters can be heard in the County Commission Meeting Room, North Wing, County Courthouse located at 945 North Temple Avenue, Starke, Florida. A copy of the ordinance may be inspected by any member of the public at the Office of the County Manager located at 945 North Temple Avenue, Starke, Florida, North Wing, County Courthouse, during regular business hours. On the date, time, and place first above mentioned, all interested persons may appear and be heard with respect to the ordinance. The title of said ordinance read, as follows:

AN ORDINANCE OF THE BOARD OF COUNTY COMMISSIONERS OF BRADFORD COUNTY, FLORIDA, AMENDING THE PURCHASING POLICY, SPECIFICALLY CHAPTER 2 – ADMINISTRATION, ARTICLE IV - PURCHASING PROCEDURES, SECTIONS 2-151 THROUGH 2-172 OF THE BRADFORD COUNTY CODE OF ORDINANCES; AND PROVIDING AN EFFECTIVE DATE.

All persons are advised that if they decide to appeal any decision made at the above reference public hearing, they will need a record of the proceedings, and that, for such purpose, they may need to ensure that a verbatim record of the proceedings is made, which record includes the testimony and evidence upon which the appeal is to be based. Persons with disabilities requesting reasonable accommodation to participate in these proceedings should contact the office of the County Manager at 904.966.6327 by 5:00 PM at least 48 hours prior to the public hearing or via Florida Relay Service 800.955.8770 (voice) or 800.955.8771 (TTY).

BOARD OF COUNTY COMMISSIONERS OF BRADFORD COUNTY, FLORIDA

AGENDA ITEM INFORMATION SHEET

DATE: April 7, 2026

AGENDA ITEM: SHIP Rehabilitation Loan Approval

DEPARTMENT: Community Development/SHIP

PURPOSE/DESCRIPTION: The SHIP Home Repair Loan program allows income qualified applicants to apply for funds in an amount not to exceed \$35,000.00.

Upon BOCC approval of SHIP Home Repair Loans application – File 2022-3 the next steps in executing these projects include: 1) Title Search, 2) Initial inspection 3) A bid advertisement for home repairs; 4) Award of bid to a contractor; and 5) Enter into an agreement with a contractor to perform home repairs. All steps will come before the BOCC for approval.

ASSOCIATED COST(S): \$35,000

BUDGET LINE (G/L #): 102-52-554-65980-00

BRADFORD COUNTY COMMUNITY DEVELOPMENT
S.H.I.P. PROGRAM
925-E NORTH TEMPLE AVENUE
STARKE, FL 32091

Based on the 2025 income limits for the Bradford County Metropolitan Statistical Area (MSA), the family or individual(s) named below is/are eligible to receive S.H.I.P. Program funds under the provisions of Chapter 420, Part V, Florida Statutes.

Home Repair Loans

Five Year Deferred Payment Loan in an Amount not to Exceed \$35,000

Pauline Lemire File # 2022-3
6487 NW CR 125
Lawtey, FL 32058
Loan Amount = \$35,000

Purchase Assistance Loans

Deferred Payment Loan in an Amount Not to exceed \$30,000

None at this Time

Loans Approved at County Commission meeting.
Date: April 7, 2026

Carolyn Spooner, Chairperson

BOARD OF COUNTY COMMISSIONERS OF BRADFORD COUNTY, FLORIDA

AGENDA ITEM INFORMATION SHEET (AIIS)

DATE OF MEETING: April 7, 2026

AGENDA ITEM Bradford County Board of County Commissioners meeting minutes from March 3, 2026.

DEPARTMENT: Clerk of Court

BOARD OF COUNTY COMMISSIONERS OF BRADFORD COUNTY, FLORIDA

March 3, 2026

9:30 A.M.

Bradford County Courthouse

945 North Temple Avenue

Starke, Florida 32091

MEETING MINUTES

BOARD MEMBERS PRESENT: Commissioner Kenny Thompson – District 2
Commissioner Joseph C. Dougherty – District 3
Commissioner Danny Riddick – District 4

BOARD MEMBERS NOT PRESENT: Chair Carolyn Spooner – District 1
Vice-Chair Diane Andrews – District 5

PRESS PRESENT: Bradford County Telegraph

STAFF MEMBERS IN ATTENDANCE: County Manager Scott Kornegay; Administrative Assistant Taylor McCoy; County Attorney Rob Bradley; Clerk Denny Thompson; Chief Deputy Clerk Rachel Rhoden; Sheriff Gordon Smith; Col. Brad Smith; Solid Waste Director Bennie Jackson; Public Works Director Jason Dodds; and Fire Rescue Chief Ben Carter.

1. **CALL TO ORDER:** County Attorney Rob Bradley called the meeting to order at 9:30 a.m. Commissioner Riddick asked the board to select which commissioner it would like to chair the meeting in the absence of Chair Spooner and Vice-Chair Andrews; the board was in **CONSENSUS** to have Commissioner Riddick chair the meeting.

2. PUBLIC COMMENTS MADE BY:

- Cindy Gordon
- Paul Still
- Kate Ellison
- Robin Frazer
- Susan Brotherton
- Maria Geer
- Marc Frazer
- Monique Costantino
- Carol Mosley
- Nansea Markham

3. APPROVAL OF CONSENT AGENDA

- A. BRADFORD COUNTY BOARD OF COUNTY COMMISSIONERS MEETING MINUTES FROM FEBRUARY 3, 2026.**
- B. BRADFORD COUNTY BOARD OF COUNTY COMMISSIONERS LAND DEVELOPMENT REGULATIONS (LDR) AND EVALUATION APPRAISAL REPORT (EAR) WORKSHOP MINUTES FROM FEBRUARY 3, 2026.**
- C. BRADFORD COUNTY BOARD OF COUNTY COMMISSIONERS MEETING MINUTES FROM FEBRUARY 19, 2026.**

- D. APPROVAL OF A STATE HOUSING INITIATIVES PARTNERSHIP PROGRAM (SHIP)/ COMMUNITY DEVELOPMENT BLOCK GRANT (CDBG) SATISFACTION OF MORTGAGE ON UNIT 16-03-CONTRACT NO. 18DB-OM-03-14-01-H09; LOAN EXPIRED.**
- E. TOURISM DEVELOPMENT COUNCIL (TDC) ADVERTISEMENT ASSISTANCE GRANT FOR BRADFORD SPORTSMEN'S FARM, THE FLORIDA CHALLENGE 2026 - \$4,000 (TDC APPROVED 2-19-2025).**
- F. AMENDMENT TO PURCHASE ORDER AGREEMENT 101 (PO 135) WITH LUTHERAN SERVICES FLORIDA (LSF) REGARDING LANGUAGE CHANGE UNDER SECTION 4.1.1 AND 4.1.2. TO REMOVE EXEMPTION OF FLORIDA DEPARTMENT OF CHILDREN AND FAMILIES (DCF) CLEARINGHOUSE LEVEL 2 EMPLOYMENT SCREENING STANDARDS PER FLORIDA STATUTE FOR EMERGENCY MEDICAL RESPONDERS AND LAW ENFORCEMENT OFFICERS, RETROACTIVE TO 11-1-2025.**
- G. REVISION TO THE FIRST AMENDMENT TO INTERLOCAL AGREEMENT REGARDING LOCAL WORKFORCE DEVELOPMENT AREA 26. TO REVISE THE QUORUM REQUIREMENT AND RELATED MEETING PROVISIONS FOR THE CAREERSOURCE NORTH CENTRAL FLORIDA (CSNCFL) COUNCIL OF ELECTED OFFICIALS.**
- H. INTERLOCAL AGREEMENT BETWEEN BRADFORD COUNTY BOARD OF COUNTY COMMISSIONERS AND KEYSTONE HEIGHTS AIRPORT AUTHORITY FOR THE CONSTRUCTION MANAGEMENT OF FLORIDA COMMERCE GRANT AGREEMENT HL339.**
- I. AN EMERGENCY ORDER ISSUED BY THE BOARD OF COUNTY, COMMISSIONERS OF BRADFORD COUNTY, FLORIDA, DECLARING A LOCAL STATE OF EMERGENCY AND IMPOSING A BURN BAN IN BRADFORD COUNTY, FLORIDA PURSUANT TO SECTION 252.38, FLORIDA STATUTES; PROVIDING FOR AN IMMEDIATE EFFECTIVE DATE. (FEBRUARY 24, 2026 – MARCH 3, 2026)**
- J. LETTER OF SUPPORT FOR FLORIDA FISH AND WILDLIFE CONSERVATION COMMISSION AND COLUMBIA COUNTY AGREEMENT TO ESTABLISH THE GATEWAY OUTDOOR EDUCATION CENTER.**
- K. A RESOLUTION OF THE BOARD OF COUNTY COMMISSIONERS OF BRADFORD COUNTY FLORIDA, PROVIDING FOR A STANDARD SCHEDULE OF FEES FOR PERMITS AND SERVICES ISSUED AND PROVIDED BY THE BRADFORD COUNTY BUILDING DEPARTMENT; PROVIDING A BASIS FOR THE CALCULATION OF CERTAIN BUILDING AND FIRE PERMIT FEES; PROVIDING A METHOD FOR THE DETERMINATION OF THE VALUE OF PERMITTED WORK; PROVIDING A MINIMUM FEE FOR BUILDING AND FIRE PERMITS; PROVIDING EXEMPTIONS FROM REQUIRED FEES FOR PERMITS AND SERVICES; PROVIDING FOR THE COLLECTION AND ADMINISTRATION OF THE REQUIRED FEES FOR PERMITS AND SERVICES; PROVIDING DEFINITIONS FOR TERMS; PROVIDING FOR SEVERABILITY; REPEALING AND REPLACING RESOLUTION 2019-62; PROVIDING FOR THE REPEAL OF OTHER INCONSISTENT ARTICLES; PROVIDING DIRECTION TO STAFF; AND PROVIDING AN EFFECTIVE DATE.**

L. BRADFORD COUNTY SHERIFF'S OFFICE PUBLIC SAFETY SPRING 2026 RURAL GRANT APPLICATION FOR CONTINUED SUPPORT OF ITS 911 SYSTEMS (AK SOLACOM SUPPORT; ESRI; AND AK IIC SUPPORT) – GRANT TOTAL \$36,097.27 (NO COUNTY MATCH).

It was MOVED by Commissioner Dougherty and SECONDED by Commissioner Thompson to approve the consent agenda.

MOTION CARRIES 3/0

4. APPOINTMENT OF A REPRESENTATIVE FOR THE BRADFORD COUNTY BOARD OF COUNTY COMMISSIONERS (BOCC) TO THE SUWANNEE RIVER ECONOMIC COUNCIL, INC. BOARD OF DIRECTORS (SREC).

Mr. Kornegay advised that the BOCC's past representative Janice Johnson has stepped down from serving on the SREC board and recommended that Community Paramedic David Weeks serve as the BOCC's new representative. Mr. Weeks agreed to serve.

It was MOVED by Commissioner Dougherty and SECONDED by Commissioner Thompson to appoint David Weeks to serve on the Suwannee River Economic Council Board of Directors.

MOTION CARRIES 3/0

Discussion: none

5. CLERK REPORTS – DENNY THOMPSON

- **CITIZEN MEMBER VACANCY ON THE BRADFORD COUNTY VALUE ADJUSTMENT BOARD.**

Clerk Thompson recognized Chief Deputy Clerk Rachel Rhoden who advised the board that it will need to appoint a new citizen member to replace Matthew Carlton on the Value Adjustment Board. She shared that a citizen member appointed by the county governing body must own homestead property in the county and must not be a member or employee of any taxing authority in Florida, or represent owners, property appraisers, tax collectors or taxing authorities in any administrative or judicial review of property taxes. Ms. Rhoden asked the board to share recommendations and appoint a qualified citizen member during its Tuesday, April 7, 2026 county commission meeting.

Discussion: none

6. SHERIFF REPORTS – GORDON SMITH

- Positive comments about the Bradford County Fair.
- Comments about the Douglas Building and its potential use as an ICE facility are as follows:
 - The opportunity came to his attention when he was approached on July 25, 2025 by a friend and former colleague who served as chief deputy in Osceola County about Sabot.
 - Shared immigration violation offense information in the United States.

- He has visited ICE facilities with favorable conditions.
- The proposed ICE facility was introduced to the board as a proposal for discussion and evaluation; no commitment or agreement has been made.
- Shared that studies of similar rural detention facilities in other counties have shown a neutral or positive economic impact.
- No person would ever be housed on land without proper environmental studies performed by the Florida Department of Environmental Protection (DEP).
- He is responsible for evaluating opportunities to strengthen public safety in the community.
- The ICE facility proposal has the potential to create jobs, generate revenue, and improve existing infrastructure.
- Florida was not reimbursed by the federal government (for construction of “Alligator Alcatraz”) because it did not follow the proper procedures.
- The GEO Group runs the ICE detention facility in Baker County.
- Addressed public comments from prior board meeting made by Paul Still regarding the ICE facility proposal.

7. COUNTY MANAGER REPORTS – SCOTT KORNEGAY

- Reported on the success of the Bradford County Fair.
- During the April 16, 2026 commission meeting, the county manager progress report will be given.
- The budget workshop that was scheduled after this meeting is canceled because two county commissioners are not available to participate.
- The next budget workshop is April 7, 2026.

8. COUNTY ATTORNEY REPORTS – RICHARD KOMANDO – none

9. COMMISSIONER’S COMMENTS

Commissioner Thompson

- Thanked the public for their participation in the meeting.
- Shared positive comments about the Bradford County Fair.
- Asked everyone to pray for Chair Spooner’s family.

Commissioner Dougherty

- Asked everyone to pray for Chair Spooner’s family.

Commissioner Riddick

- Shared positive comments about the Bradford County Fair.
- Commended Bradford County Fire Rescue for their response to brush fires during the burn ban.
- Announced upcoming meeting as follows:
 - Commission Meeting: March 19, 2026 at 6:30 p.m.
 - Commission Meeting: April 7, 2026 at 9:30 a.m.
 - Budget Workshop: April 7, 2026 at 10:30 a.m.
 - Commission Meeting: April 16, 2026 at 6:30 p.m.

March 3, 2026
BoCC Meeting Minutes

ADJOURN: There being no further business, the meeting adjourned at 10:28 a.m.

**BOARD OF COUNTY COMMISSIONERS
BRADFORD COUNTY, FLORIDA**

CAROLYN SPOONER, CHAIR

ATTEST:

DENNY THOMPSON, CLERK TO THE BOARD

MINUTES PREPARED BY:

RACHEL RHODEN, CHIEF DEPUTY CLERK

BOARD OF COUNTY COMMISSIONERS OF BRADFORD COUNTY, FLORIDA

AGENDA ITEM INFORMATION SHEET (AIIS)

DATE OF MEETING: April 7, 2026

AGENDA ITEM Bradford County Board of County Commissioners meeting minutes from March 19, 2026.

DEPARTMENT: Clerk of Court

BOARD OF COUNTY COMMISSIONERS OF BRADFORD COUNTY, FLORIDA

March 19, 2026

6:30 P.M.

Bradford County Courthouse

945 North Temple Avenue

Starke, Florida 32091

MEETING MINUTES

BOARD MEMBERS PRESENT: Chair Carolyn Spooner – District 1
Vice-Chair Diane Andrews – District 5
Commissioner Kenny Thompson – District 2
Commissioner Joseph C. Dougherty – District 3

BOARD MEMBERS NOT PRESENT: Commissioner Danny Riddick – District 4

PRESS PRESENT: none

STAFF MEMBERS IN ATTENDANCE: County Manager Scott Kornegay; Executive Assistant Amanda Brown; County Attorney Richard Komando; Chief Deputy Clerk Rachel Rhoden; and Sheriff Gordon Smith

1. CALL TO ORDER: Chair Spooner called the meeting to order at 6:30 p.m.

2. PUBLIC COMMENTS:

- Tonja Haisten
- Kristin Rubin
- Marie Geer
- Carol Mosley
- Paul Still
- Stephen Winekoff
- Josh Cooper
- Kate Ellison
- Vonda Strong
- Scott Belford

3. APPROVAL OF CONSENT AGENDA

- A. PUBLIC SAFETY SYSTEM MANAGEMENT GRANT APPLICATION (\$8,880).**
- B. AN EMERGENCY ORDER ISSUED BY THE BOARD OF COUNTY, COMMISSIONERS OF BRADFORD COUNTY, FLORIDA, DECLARING A LOCAL STATE OF EMERGENCY AND IMPOSING A BURN BAN IN BRADFORD COUNTY, FLORIDA PURSUANT TO SECTION 252.38, FLORIDA STATUTES; PROVIDING FOR AN IMMEDIATE EFFECTIVE DATE. (MARCH 3, 2026 – MARCH 9, 2026)**
- C. AN EMERGENCY ORDER ISSUED BY THE BOARD OF COUNTY, COMMISSIONERS OF BRADFORD COUNTY, FLORIDA, DECLARING A LOCAL STATE OF EMERGENCY AND IMPOSING A BURN BAN IN BRADFORD COUNTY, FLORIDA PURSUANT TO SECTION 252.38, FLORIDA STATUTES; PROVIDING FOR AN IMMEDIATE EFFECTIVE DATE. (MARCH 10, 2026 – MARCH 16, 2026)**
- D. APPROVAL OF MOBILE COMMUNICATION AMERICA (MCA) INVOICE FOR A PAGING SYSTEM USED BY LAWTEY FIRE (\$990.56).**

- E. APPROVAL OF L3HARRIS QUARTERLY INVOICE FOR RADIOS (\$7,695).**
- F. FIRE ASSESSMENT ADJUSTMENTS AND HARDSHIP APPLICATIONS.**
- G. RATIFICATION OF PAYMENT REGISTER(S) FROM 12-6-25 THRU 3-6-26.**
- H. A RESOLUTION OF THE BOARD OF COUNTY COMMISSIONERS OF BRADFORD COUNTY, FLORIDA, AMENDING RESOLUTION 2019-62; PROVIDING FOR REVISIONS TO THE ADOPTED SCHEDULE OF FEES AND CHARGES FOR MATTERS PERTAINING TO THE COUNTY'S COMPREHENSIVE PLAN AND LAND DEVELOPMENT REGULATIONS; PROVIDING FOR REPEAL OF ALL RESOLUTIONS IN CONFLICT; PROVIDING FOR SEVERABILITY; AND PROVIDING FOR AN EFFECTIVE DATE.**
- I. RETROACTIVE APPROVAL OF THE UPDATED COMMUNITY PLANNING TECHNICAL ASSISTANCE (CPTA) GRANT AGREEMENT WITH THE STATE OF FLORIDA, DEPARTMENT OF COMMERCE.**
- J. STATE OF FLORIDA, DEPARTMENT OF COMMERCE GRANT AGREEMENT NO: MS005 FOR SW 163RD STREET IMPROVEMENTS.**

It was **MOVED** by Commissioner Dougherty and **SECONDED** by Commissioner Thompson to approve the consent agenda.

MOTION CARRIES 4/0

4. COMCAST PRESENTATION ON SERVICES AND EXPANSION INTO BRADFORD COUNTY – SAMUEL WALTZER, GOVERNMENT AND REGULATORY AFFAIRS.

Chair Spooner recognized Mr. Waltzer who shared a PowerPoint presentation highlighting the following:

- Services include mobile services, Xfinity to residential, and Comcast to businesses.
- Background in Comcast investing in communities across America.
- Through federal Broadband Equity and Deployment (BEAD) grants, Comcast is partnering with Florida to bring broadband to underserved communities.
- Approximately 4,335 Bradford County homes and businesses are expected to be connected to Xfinity.

Discussion:

- Broadband at the southern end of Starke, towards Walmart, is expected by the end of the year, if services are not provided already.
- Another BEAD bill is expected in the coming years to help continue broadband expansion.
- Broadband connectivity has expanded into Brooker.
- Mr. Kornegay thanked Mr. Waltzer for keeping county staff informed of future construction plans.
- Cox may possibly convert to fiber and reach underserved areas as well.

5. CLERK REPORTS – DENNY THOMPSON

Chief Deputy Clerk Rachel Rhoden reminded the board that it will need to appoint a new citizen member to replace Matthew Carlton on the Value Adjustment Board. She shared that a citizen member appointed by the county governing body must own homestead property in the county and must not be a member or employee of

any taxing authority in Florida, or represent owners, property appraisers, tax collectors or taxing authorities in any administrative or judicial review of property taxes. Ms. Rhoden asked the board to share recommendations and appoint a qualified citizen member during its Tuesday, April 7, 2026 county commission meeting.

Discussion: none

6. SHERIFF REPORTS – GORDON SMITH

- Comments in support of a professionally maintained and operated ICE facility that has the potential to bring revenue into Bradford County.

Discussion:

- Due to several vehicle crashes, Chair Spooner suggested that a DOT (Florida Department of Transportation) study is needed at the intersection US 301 and the bypass while discussions regarding the proposed ICE detention facility continue.
- Chair Spooner and Sheriff Smith acknowledged and commended Lt. (David) Weeks for his outreach (Community Paramedicine Program) to jail inmates.
- Chair Spooner thanked Capt. (Brad) Witt for his response during recent storm events.

7. COUNTY MANAGER REPORTS – SCOTT KORNEGAY

- A community workshop is scheduled for March 24, 2026 from 5:30 p.m. to 7:00 p.m. at the Charley E. Johns Conference Center to get feedback on updating the Bradford County Comprehensive Plan and Strategic Plan.
- Bradford Sports United has had great success in signing up kids.
- During the past week, the Bradford County Public Works Department participated in the Jacksonville public rodeo, where employee Heath Beckner was the overall winner.
- Burn ban will remain in effect until further notice.
- County manager's annual progress report will be given during the April 16, 2026 meeting.

8. COUNTY ATTORNEY REPORTS – RICHARD KOMANDO – none

9. COMMISSIONER'S COMMENTS

Vice Chair Andrews

- Positive comments about the Bradford County Fair.
- Asked to keep the military in everyone's prayers.
- Expressed joy at Chair Spooner's return to work.

Commissioner Thompson

- Thanked the public for participating in the meeting.
- Positive comments about the Bradford County Fair.
- Thanked the sheriff and his staff for their hard work in the community.

Commissioner Dougherty

- Expressed joy at Chair Spooner’s return to work.
- Recognized Roman Alvarez, Sheriff Smith's late father-in-law, for his support of Laredo’s Restaurant employees.
- April 10, 2026 is the Shoot for the Sheriff event to raise funds for the community.
- Shared his appreciation to all first responders and support staff.

Chair Spooner

- Thanked everyone for their prayers for her and family.
- Shared appreciation to Sheriff Smith, Capt. (Brad) Witt, and public works for their response during recent storm events.
- Thanked finance staff for preparing for upcoming budget workshops.
- Encouraged community participation in the scheduled community workshop to discuss strategic planning.
- Expressed the importance of following the burn ban.
- Interested in reviewing the study prepared by public comment speaker Scott Belford.
- Recognized Chief Deputy Clerk Rachel Rhoden for her Boy Scouts of America award.

ADJOURN: There being no further business, the meeting adjourned at 7:47 p.m.

**BOARD OF COUNTY COMMISSIONERS
BRADFORD COUNTY, FLORIDA**

CAROLYN SPOONER, CHAIR

ATTEST:

DENNY THOMPSON, CLERK TO THE BOARD

MINUTES PREPARED BY:

RACHEL RHODEN, CHIEF DEPUTY CLERK

BOARD OF COUNTY COMMISSIONERS OF BRADFORD COUNTY, FLORIDA

AGENDA ITEM INFORMATION SHEET

DATE: April 7, 2026

AGENDA ITEM Confirmation of (Burn Ban)
AN EMERGENCY ORDER ISSUED BY THE BOARD OF, COMMISSIONERS OF BRADFORD COUNTY, FLORIDA, DECLARING A LOCAL STATE OF EMERGENCY AND IMPOSING A BURN BAN IN BRADFORD COUNTY, FLORIDA PURSUANT TO SECTION 252.38, FLORIDA STATUTES; PROVIDING FOR AN IMMEDIATE EFFECTIVE DATE. (March 17, 2026 – March 23, 2026)

DEPARTMENT: Emergency Management

PURPOSE: This emergency order imposes a burn ban in Bradford County from March 17, 2026 – March 23, 2026

ASSOCIATED COST(S):

BUDGET LINE (G/L #):

BOARD OF COUNTY COMMISSIONERS OF BRADFORD COUNTY, FLORIDA

EMERGENCY ORDER 2026-07

AN EMERGENCY ORDER ISSUED BY THE BOARD OF COUNTY COMMISSIONERS OF BRADFORD COUNTY, FLORIDA, DECLARING A LOCAL STATE OF EMERGENCY AND IMPOSING A BURN BAN IN BRADFORD COUNTY, FLORIDA PURSUANT TO SECTION 252.38, FLORIDA STATUTES; PROVIDING FOR AN IMMEDIATE EFFECTIVE DATE.

WHEREAS, the Board of County Commissioners of Bradford County, Florida codified in Chapter 26 of the Bradford County Code of Ordinances (“the Code”) the authority to invoke the powers provided for in Chapter 252, Florida Statutes; and

WHEREAS, pursuant to Section 26-8(a) of the Code, the County Commission granted authority to the Chair of the Board of County Commissioners to declare a state of local emergency from time to time when it is determined that conditions exist giving rise to such a declaration; and

WHEREAS, pursuant to Section 26-8(d) of the Code, authorizes emergency declarations include the prohibition of open fires and other burn restrictions; and

WHEREAS, the Keetch-Byram Drought Index, a soil moisture measurement in which a measurement of 400 denotes a significant danger of fire, and has Bradford County currently measured at 591, with drought conditions expected to remain high to very high for the month of February; and

WHEREAS, The U.S. Drought Monitor is a joint effort of the National Drought Mitigation Center, U.S. Department of Agriculture, and National Oceanic and Atmospheric Administration. The U.S. Drought Monitor depicts the location and intensity of drought across the country using 5 classifications: Abnormally Dry (D0), showing areas that may be going into or are coming out of drought, and four levels of drought (D1–D4). The U.S. Drought Monitor denotes Bradford County Florida as: D1 – Moderate Drought 100%; and

WHEREAS, according to the National Weather Service in Jacksonville, Florida, Bradford County is currently experiencing weather conditions such as an unusually early season freeze, and recent above normal high temperatures that will lead to further drying of soil conditions with little rain on the horizon; and

WHEREAS, the current and forecasted weather conditions increase the probability of dangerous wildfires and a review of all relevant factors indicates the current conditions pose a severe threat to Bradford County, Florida; and

WHEREAS, on March 10, 2026, Scott Kornegay, County Manager, issued this Emergency Order declaring a state of local emergency in Bradford County, Florida, and issuing a ban on burning which may lead to the loss of life and / or property.

NOW THEREFORE, the above recitals are hereby adopted and incorporated into this Emergency Order pursuant to the Code, Chapter 252, Florida Statutes, and to the authority provided this Emergency Order, dated March 15, 2026, declaring a state of local emergency in Bradford County, Florida, and as follows:

- (1) A burn ban is imposed in the entirety of Bradford County, Florida.
- (2) The outdoor burning of yard trash, household paper products, bonfires, campfires, warming fires, outdoor fireplaces, chimeneas, and cooking fires is prohibited unless: 1) authorized by the Florida Forest Service; or 2) for the cooking of food exclusively within a contained gas or charcoal grill.
- (3) The setting of fires to any grass, brush, or forest covered land, is prohibited unless authorized by the Florida Forest Service.
- (4) Any person, firm, partnership or corporation who violates the provisions of this Emergency Order, unless an exemption is approved or granted by the Florida Forest Service, shall be guilty of a second degree misdemeanor, punishable as provided in Chapter

775.083, Florida Statutes, or, in the case of individuals, the members of a partnership and the responsible officers and agents of an association or corporation, punishable as provided in Sections 775.082 or 775.083, Florida Statutes.

PROCLAIMED and ORDERED for the period commencing on **March 17, 2026**, and continuing through **March 23, 2026**.

Board of County Commissioners
Bradford County, Florida



Scott Kornegay, County Manager

BOARD OF COUNTY COMMISSIONERS OF BRADFORD COUNTY, FLORIDA

AGENDA ITEM INFORMATION SHEET

DATE: April 7, 2026

AGENDA ITEM Confirmation of (Burn Ban)
AN EMERGENCY ORDER ISSUED BY THE BOARD OF, COMMISSIONERS OF BRADFORD COUNTY, FLORIDA, DECLARING A LOCAL STATE OF EMERGENCY AND IMPOSING A BURN BAN IN BRADFORD COUNTY, FLORIDA PURSUANT TO SECTION 252.38, FLORIDA STATUTES; PROVIDING FOR AN IMMEDIATE EFFECTIVE DATE. (March 24, 2026 – March 30, 2026)

DEPARTMENT: Emergency Management

PURPOSE: This emergency order imposes a burn ban in Bradford County from March 24, 2026 – March 30, 2026

ASSOCIATED COST(S):

BUDGET LINE (G/L #):

BOARD OF COUNTY COMMISSIONERS OF BRADFORD COUNTY, FLORIDA

EMERGENCY ORDER 2026-08

AN EMERGENCY ORDER ISSUED BY THE BOARD OF COUNTY COMMISSIONERS OF BRADFORD COUNTY, FLORIDA, DECLARING A LOCAL STATE OF EMERGENCY AND IMPOSING A BURN BAN IN BRADFORD COUNTY, FLORIDA PURSUANT TO SECTION 252.38, FLORIDA STATUTES; PROVIDING FOR AN IMMEDIATE EFFECTIVE DATE.

WHEREAS, the Board of County Commissioners of Bradford County, Florida codified in Chapter 26 of the Bradford County Code of Ordinances (“the Code”) the authority to invoke the powers provided for in Chapter 252, Florida Statutes; and

WHEREAS, pursuant to Section 26-8(a) of the Code, the County Commission granted authority to the Chair of the Board of County Commissioners to declare a state of local emergency from time to time when it is determined that conditions exist giving rise to such a declaration; and

WHEREAS, pursuant to Section 26-8(d) of the Code, authorizes emergency declarations include the prohibition of open fires and other burn restrictions; and

WHEREAS, the Keetch-Byram Drought Index, a soil moisture measurement in which a measurement of 400 denotes a significant danger of fire, and has Bradford County currently measured at 591, with drought conditions expected to remain high to very high for the month of February; and

WHEREAS, The U.S. Drought Monitor is a joint effort of the National Drought Mitigation Center, U.S. Department of Agriculture, and National Oceanic and Atmospheric Administration. The U.S. Drought Monitor depicts the location and intensity of drought across the country using 5 classifications: Abnormally Dry (D0), showing areas that may be going into or are coming out of drought, and four levels of drought (D1–D4). The U.S. Drought Monitor denotes Bradford County Florida as: D1 – Moderate Drought 100%; and

WHEREAS, according to the National Weather Service in Jacksonville, Florida, Bradford County is currently experiencing weather conditions such as an unusually early season freeze, and recent above normal high temperatures that will lead to further drying of soil conditions with little rain on the horizon; and

WHEREAS, the current and forecasted weather conditions increase the probability of dangerous wildfires and a review of all relevant factors indicates the current conditions pose a severe threat to Bradford County, Florida; and

WHEREAS, on March 16, 2026, Scott Kornegay, County Manager, issued this Emergency Order declaring a state of local emergency in Bradford County, Florida, and issuing a ban on burning which may lead to the loss of life and / or property.

NOW THEREFORE, the above recitals are hereby adopted and incorporated into this Emergency Order pursuant to the Code, Chapter 252, Florida Statutes, and to the authority provided this Emergency Order, dated March 15, 2026, declaring a state of local emergency in Bradford County, Florida, and as follows:

- (1) A burn ban is imposed in the entirety of Bradford County, Florida.
- (2) The outdoor burning of yard trash, household paper products, bonfires, campfires, warming fires, outdoor fireplaces, chimeneas, and cooking fires is prohibited unless: 1) authorized by the Florida Forest Service; or 2) for the cooking of food exclusively within a contained gas or charcoal grill.
- (3) The setting of fires to any grass, brush, or forest covered land, is prohibited unless authorized by the Florida Forest Service.
- (4) Any person, firm, partnership or corporation who violates the provisions of this Emergency Order, unless an exemption is approved or granted by the Florida Forest Service, shall be guilty of a second degree misdemeanor, punishable as provided in Chapter

775.083, Florida Statutes, or, in the case of individuals, the members of a partnership and the responsible officers and agents of an association or corporation, punishable as provided in Sections 775.082 or 775.083, Florida Statutes.

PROCLAIMED and ORDERED for the period commencing on **March 24, 2026**, and continuing through **March 30, 2026**.

Board of County Commissioners
Bradford County, Florida

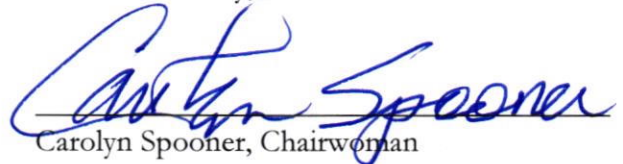

Carolyn Spooner, Chairwoman

BOARD OF COUNTY COMMISSIONERS OF BRADFORD COUNTY, FLORIDA

AGENDA ITEM INFORMATION SHEET

DATE: April 7, 2026

AGENDA ITEM Confirmation of (Burn Ban)
AN EMERGENCY ORDER ISSUED BY THE BOARD OF, COMMISSIONERS OF BRADFORD COUNTY, FLORIDA, DECLARING A LOCAL STATE OF EMERGENCY AND IMPOSING A BURN BAN IN BRADFORD COUNTY, FLORIDA PURSUANT TO SECTION 252.38, FLORIDA STATUTES; PROVIDING FOR AN IMMEDIATE EFFECTIVE DATE. (March 31, 2026 – April 6 , 2026)

DEPARTMENT: Emergency Management

PURPOSE: This emergency order imposes a burn ban in Bradford County from March 31, 2026 – April 6, 2026

ASSOCIATED COST(S):

BUDGET LINE (G/L #):

BOARD OF COUNTY COMMISSIONERS OF BRADFORD COUNTY, FLORIDA

EMERGENCY ORDER 2026-09

AN EMERGENCY ORDER ISSUED BY THE BOARD OF COUNTY COMMISSIONERS OF BRADFORD COUNTY, FLORIDA, DECLARING A LOCAL STATE OF EMERGENCY AND IMPOSING A BURN BAN IN BRADFORD COUNTY, FLORIDA PURSUANT TO SECTION 252.38, FLORIDA STATUTES; PROVIDING FOR AN IMMEDIATE EFFECTIVE DATE.

WHEREAS, the Board of County Commissioners of Bradford County, Florida codified in Chapter 26 of the Bradford County Code of Ordinances (“the Code”) the authority to invoke the powers provided for in Chapter 252, Florida Statutes; and

WHEREAS, pursuant to Section 26-8(a) of the Code, the County Commission granted authority to the Chair of the Board of County Commissioners to declare a state of local emergency from time to time when it is determined that conditions exist giving rise to such a declaration; and

WHEREAS, pursuant to Section 26-8(d) of the Code, authorizes emergency declarations include the prohibition of open fires and other burn restrictions; and

WHEREAS, the Keetch-Byram Drought Index, a soil moisture measurement in which a measurement of 400 denotes a significant danger of fire, and has Bradford County currently measured at 591, with drought conditions expected to remain high to very high for the month of February; and

WHEREAS, The U.S. Drought Monitor is a joint effort of the National Drought Mitigation Center, U.S. Department of Agriculture, and National Oceanic and Atmospheric Administration. The U.S. Drought Monitor depicts the location and intensity of drought across the country using 5 classifications: Abnormally Dry (D0), showing areas that may be going into or are coming out of drought, and four levels of drought (D1–D4). The U.S. Drought Monitor denotes Bradford County Florida as: D1 – Moderate Drought 100%; and

WHEREAS, according to the National Weather Service in Jacksonville, Florida, Bradford County is currently experiencing weather conditions such as an unusually early season freeze, and recent above normal high temperatures that will lead to further drying of soil conditions with little rain on the horizon; and

WHEREAS, the current and forecasted weather conditions increase the probability of dangerous wildfires and a review of all relevant factors indicates the current conditions pose a severe threat to Bradford County, Florida; and

WHEREAS, on March 24, 2026, Carolyn Spooner, Chairwoman of the Board of County Commissioners of Bradford County, Florida issued this Emergency Order declaring a state of local emergency in Bradford County, Florida, and issuing a ban on burning which may lead to the loss of life and / or property.

NOW THEREFORE, the above recitals are hereby adopted and incorporated into this Emergency Order pursuant to the Code, Chapter 252, Florida Statutes, and to the authority provided this Emergency Order, dated March 24, 2026, declaring a state of local emergency in Bradford County, Florida, and as follows:

- (1) A burn ban is imposed in the entirety of Bradford County, Florida.
- (2) The outdoor burning of yard trash, household paper products, bonfires, campfires, warming fires, outdoor fireplaces, chimeneas, and cooking fires is prohibited unless: 1) authorized by the Florida Forest Service; or 2) for the cooking of food exclusively within a contained gas or charcoal grill.
- (3) The setting of fires to any grass, brush, or forest covered land, is prohibited unless authorized by the Florida Forest Service.
- (4) Any person, firm, partnership or corporation who violates the provisions of this Emergency Order, unless an exemption is approved or granted by the Florida Forest

Service, shall be guilty of a second degree misdemeanor, punishable as provided in Chapter 775.083, Florida Statutes, or, in the case of individuals, the members of a partnership and the responsible officers and agents of an association or corporation, punishable as provided in Sections 775.082 or 775.083, Florida Statutes.

PROCLAIMED and ORDERED for the period commencing on **March 31, 2026**, and continuing through **April 6, 2026**.

Board of County Commissioners
Bradford County, Florida

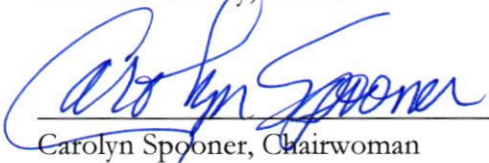

Carolyn Spooner, Chairwoman

BOARD OF COUNTY COMMISSIONERS OF BRADFORD COUNTY, FLORIDA

AGENDA ITEM INFORMATION SHEET

DATE: April 7, 2026

AGENDA ITEM: Site Access Agreement with Florida Department of Environmental Protection for monitoring of the “Douglas Building” Property – 14281 US Hwy 301 South, Starke, Florida

DEPARTMENT: County Manager

PURPOSE: This agreement grants FDEP access to the property for the permissible activities:

- conduct soil, surface, subsurface, and groundwater investigations, including but not limited to entry by a drill rig vehicle and/or support vehicles;
- install and abandon groundwater monitoring wells;
- use geophysical equipment;
- use an auger for collecting soil and sediment samples;
- locate existing wells;
- collect waste, soil, sediment, and water samples;
- remove, treat and/or dispose of contaminated soils, sediments, and water;
- remove contaminated soil by digging with backhoes, large diameter augers and similar equipment;
- install, operate, and remove remedial equipment;
- install and remove utility connections;
- trenching for connection of remediation wells to equipment; and
- conduct surveys, prepare site sketches, and take photographs.



SITE INVESTIGATION SECTION

PERMISSION TO ENTER PROPERTY

1. The Parties. The undersigned real property owner, Bradford County (“**Property Owner**”), hereby gives permission to the State of Florida Department of Environmental Protection, (the “**Department**”), and its contractors, subcontractors, and vendors (“**Contractors**”) to enter the Owner's property located at 14281 U.S. Highway 301 South, Starke, Florida 32091.
2. The Property. Property Owner owns certain real property identified as parcel number 04712-0-00000 (13097) 03 (the “**Property**”), depicted on the attached legal description as Exhibit “A”. The Property is a contaminated site as defined in Section 376.301, F.S., specifically the former Department Management Services (DMS) facility, DEP Facility ID# ERIC_6157 (the “**Site**”). The Department has determined that state-funding may be used to address the contamination associated with this Site pursuant to Section 376.307, F.S.
3. Permissible Activities. This Site Access Agreement (“**Agreement**”) is limited to activities which may be performed by the Department or the Contractors pursuant to Chapter 62-780, Florida Administrative Code (F.A.C.), to locate contamination and determine contamination levels and, when necessary, remove and remediate contamination, which may be performed by the Department and its Contractors (“**Permissible Activities**”). Such activities may include but are not limited to:
 - conduct soil, surface, subsurface, and groundwater investigations, including but not limited to entry by a drill rig vehicle and/or support vehicles;
 - install and abandon groundwater monitoring wells;
 - use geophysical equipment;
 - use an auger for collecting soil and sediment samples;
 - locate existing wells;
 - collect waste, soil, sediment, and water samples;
 - remove, treat and/or dispose of contaminated soils, sediments, and water;
 - remove contaminated soil by digging with backhoes, large diameter augers and similar equipment;
 - install, operate, and remove remedial equipment;
 - install and remove utility connections;
 - trenching for connection of remediation wells to equipment; and
 - conduct surveys, prepare site sketches, and take photographs.
4. Duration and Termination of Access. This Permission is granted, without any fee or charge to the Department or Contractors, for so long as is necessary to assess, remove, monitor and remediate the contamination on the Property. Access shall be allowed for the Department and its Contractors immediately upon the execution of this Permission.
5. County Administrator. The County Administrator is authorized to exercise the Owner’s rights and obligations under this Agreement, including, but not limited to, giving written consent to the Department’s requests when necessary, approving any amendment or waiver of the terms and conditions of this Agreement, and terminating the Agreement. The Administrator is defined as the administrative head of County pursuant to Ordinance Number 93-08 of Bradford County and Section 125.74, F.S..
6. Activities Comply with Applicable Laws. The Department and Contractor agree that any and all work performed on the Property and in association with this Permission shall be done in a good, safe,

workmanlike manner, and in accordance with applicable federal and state statutes, rules and regulations.

7. Proper Disposal of Contaminated Media. The Department and Contractor shall ensure that soil cuttings, any work materials, and water generated shall be disposed of in accordance with Environmental Laws. All soil cuttings, waste materials and development water generated shall be promptly removed from the Property.

8. Property Restoration. The Department shall only pay the reasonable costs of restoring the Property as nearly as practicable to the conditions that existed prior to activities associated with contamination assessment or remedial action.

9. Owner's Non-Interference. The Owner shall not interfere with the Department or Contractor when performing the Permissible Activities. Owner shall not damage any equipment including wells, piping, and remediation system that may be located on the Property. Owner shall notify the Department at least thirty (30) days prior to commencement of any construction, demolition or other work on the Property that may damage or destroy any part of the equipment installed under this Agreement.

10. No Admission. The granting of this Agreement by the Owner is not intended, nor should it be construed, as an admission of liability on the part of the Owner for any contamination discovered on the Property.

11. Owner's Use of Property. The Property Owner retains the right to use the Property, and the Department will work with the Property Owner regarding minimizing activities that may interfere with the Owner's management and use of the Property. However, the Department is not responsible for any inconvenience, economic injury, or business damage that Property Owner may suffer due to the performance of any Permissible Activity.

12. Injury to Department. The Property Owner shall not be liable for any injury, damage or loss on the Property suffered by the Department or Department employees not caused by the negligence or intentional acts of the Property Owner's agents or employees.

13. Sovereign Immunity. To the extent permitted by law, and without either party waiving its sovereign immunity or waiving any limits established by Section 768.28, Florida Statutes, the Owner and the Department acknowledges and accepts their responsibility and liability for torts under applicable law (Section 768.28, Florida Statutes) for damages caused by the acts of their respective employees while on the Property.

14. Public Records. All documents created or received associated with the Permissible activities are a public record pursuant to Chapter 119, Florida Statutes. The Owner may retrieve any documents or other information related to the Permissible Activities online using the facility number reference above. <https://depdms.dep.state.fl.us/Oculus/servlet/login>

15. Environmental Infrastructure and Well Permits. The Property Owner authorizes the Department and Contractors to act as its authorized representative in signing all required forms and documents necessary for obtaining applicable permits related to environmental infrastructure improvements including well construction, repair, maintenance, modification, and abandonment pursuant to Chapter 373, F.S.

16. Entire Agreement. This Agreement shall constitute the entire agreement between the Department and the Owner regarding this grant of access to Property by the Department and its Contractors as stated herein. No modification, amendment or waiver of the terms and conditions of this Agreement shall be binding upon

Department unless approved in writing by an authorized representative of the Owner and the Department.

17. Notices. For a notice to a party to be effective under this Agreement, notice must be sent via e-mail to the addresses listed below and shall be effective upon mailing. The addresses for notice shall remain as set forth herein unless and until changed by providing notice of such change in accordance with this section.

NOTICE TO OWNER:

County Manager: Mr. Scott Kornegay

Email Address: scott_kornegay@bradfordcountyfl.gov

With a copy to:

Attorney: Bradley & Komando

Email Address: rich@claylawyers.com

and

Executive Assistant to the County Manager: Ms. Amanda Brown

Email Address: amanda_brown@bradfordcountyfl.gov

NOTICE TO DEPARTMENT:

Site Investigation Section: Jeff Newton P.G.

Email Address: jeff.newton@floridadep.gov

18. Governing Law and Venue. This Agreement shall be governed by and construed in accordance with the laws of the State of Florida. Venue for any action or proceeding arising from or relating to this Agreement shall be in the appropriate Florida court having jurisdiction located in Bradford County, Florida.
19. No Third-Party Beneficiaries. This Agreement is solely for the benefit of the parties hereto and their respective Contractors, successors, and assigns, and shall not be deemed to confer upon third parties any remedy, claim, liability, or reimbursement, claim of action or other right.
20. Severability. In the event that any part of this Agreement is found to be invalid by a court of competent jurisdiction, that part shall be severed from this Agreement, and the balance of this Agreement shall remain in full force.

[The Remainder of this Page is Intentionally Left Blank]

EXHIBIT A

That part of a parcel of land described in Deed Book 74 at Page 115 et seq., of the public records of Bradford County, Florida, lying within the following described parcel, to-wit:

A parcel of land containing 30.77 acres lying partly in the Southwest quarter (SW $\frac{1}{4}$) of Northwest quarter (NW $\frac{1}{4}$) and in the Northwest quarter (NW $\frac{1}{4}$) of Southwest quarter (SW $\frac{1}{4}$) of Section Five (5), and partly in the Southeast quarter (SE $\frac{1}{4}$) of Northeast quarter (NE $\frac{1}{4}$) and in the Northeast quarter (NE $\frac{1}{4}$) of Southeast quarter (SE $\frac{1}{4}$) of Section six, (6), all in Township seven (7) South, Range twenty-two (22) East, Bradford County, Florida and being more particularly described as follows:

Commence at the Southwest corner of aforesaid Southwest quarter (SW $\frac{1}{4}$) of Northwest quarter (NW $\frac{1}{4}$) and run thence North 0 degrees 55 minutes West along the Westerly boundary thereof a distance of 320.13 feet to a concrete monument on the Easterly boundary of the right of way of State Road 200 for Point of Beginning.

From point of beginning thus described, run North 34 degrees 25 minutes 10 seconds East along said Easterly boundary a distance of 414.08 feet to a concrete monument on the Northerly boundary of the South half (S $\frac{1}{2}$) of said SW $\frac{1}{4}$ of NW $\frac{1}{4}$; run thence South 89 degrees 45 minutes East along said Northerly boundary a distance of 474.64 feet to a concrete monument; run thence South 4 degrees 57 minutes East a distance of 72.58 feet to a concrete monument; run thence South 89 degrees 45 minutes East a distance of 620.3 feet to a concrete monument on the Easterly boundary of aforesaid SW $\frac{1}{4}$ of NW $\frac{1}{4}$; run thence South 0 degrees 36 minutes 20 seconds East along last aforesaid Easterly boundary a distance of 590.68 feet to a concrete monument on the Southeast corner of aforesaid SW $\frac{1}{4}$ of NW $\frac{1}{4}$; run thence South 1 degree 31 minutes 50 seconds East along the Easterly boundary of aforesaid NW $\frac{1}{4}$ of SW $\frac{1}{4}$ a distance of 159.6 feet to a concrete monument; run thence South 81 degrees 11 minutes 50 seconds West a distance of 1865.15 feet to a concrete monument on aforesaid Easterly boundary of the right-of-way of State Road 200; run thence in a Northeasterly direction along last aforesaid Easterly boundary and along the arc of a curve concave to the Southeast and having a radius of 5696.65 feet a chord distance of 540.87 feet to a concrete monument at the end of said curve, said chord having a bearing of North 31 degrees 41 minutes 51 seconds East; run thence North 34 degrees 25 minutes 10 seconds East a distance of 376.91 feet to Point of Beginning.

BOARD OF COUNTY COMMISSIONERS OF BRADFORD COUNTY, FLORIDA

AGENDA ITEM INFORMATION SHEET

DATE: April 6, 2026

AGENDA ITEM Updated Task Work Order with North Florida Professional Services for Zoning Services

DEPARTMENT: Zoning

PURPOSE: The updated rates are in line with the resolution passed at the 3-19-26 BOCC meeting.



TASK WORK ORDER FOR PROFESSIONAL PLANNING SERVICES

This agreement made this ____ day of _____, 2026, by and between Bradford County, Florida, a political subdivision of the State of Florida, herein referred to as the COUNTY, and North Florida Professional Services, Inc., herein after referred to as the CONSULTANT.

Project

The COUNTY requires professional planning services for the evaluation and processing of various development applications, Comprehensive Plan Future Land Use Map Updates, and Official Zoning Atlas Updates.

Scope of Services

The CONSULTANT proposes to perform the following Scope of Service:

- Review development applications for completeness;
- Review development applications for compliance with State and Federal Regulations, the County’s Comprehensive Plan, and the County’s Land Development Regulations;
- Prepare review comments;
- Prepare required advertisements for public hearings;
- Prepare resolutions and/or ordinances, as required;
- Update the Future Land Use Map of the Comprehensive Plan; and,
- Update the Official Zoning Atlas of the Land Development Regulations.

Fees

Fees shall be in accordance with Attachment “A” – Fee Schedule

Agreement

This Task Work Order constitutes a Project Agreement for the PROJECT. The CONSULTANT will perform the Scope of Services as described herein above in exchange for the fees as described herein above. This is in accordance with the Master Contract between COUNTY and CONSULTANT.

IN WITNESS THEREOF, Bradford County, Florida, through its Board of County Commissioners has caused this Task Work Order to be executed on the day and year first shown above.

BRADFORD COUNTY, FLORIDA

Attest:

BY: _____
Denny Thompson, Clerk of Court

BY: _____
Carolyn Spooner, Chair

IN WITNESS WHEREOF, North Florida Professional Services, Inc., as CONSULTANT herein, has caused this Task Work Order to be executed on the day and year first shown above.

NORTH FLORIDA PROFESSIONAL SERVICES, INC.

BY: _____
Megan Carter, Secretary/Treasurer

Exhibit "A" - Bradford County Zoning Fee Schedule

The Schedule of Fees and Charges:

A petition to –

	<u>Fee</u>
Amend the Future Land Use Plan Map of the Comprehensive Plan...	
Small Scale Amendment	\$3,480.00
Large Scale Amendment	\$6,280.00
Amend the text of the Comprehensive Plan	\$6,520.00
Amend the Official Zoning Atlas	\$3,480.00
Zoning Amendments for Planned Residential Developments of the Land Development Regulations	\$6,720.00
Amend the text of the Land Development Regulations	\$6,520.00
An appeal to the Board of Adjustment for –	
Special Exception	\$2,400.00
Variance – All other	\$1,800.00
Variance - Setback	\$250.00
Change in a Non-Conforming use	\$750.00
Interpretation (example: Appeal of the decision of the LDR Administrator)	\$750.00
An appeal of the decision of the Planning & Zoning Board and/or the Board of Adjustments	\$750.00
An application for Subdivision Plat Approval – Minor Subdivision (Planning Review Only)	\$2,100.00
An application for – Major Subdivision (Planning Review Only)	\$3,500.00
Family Lot Split	\$100.00
Certificate of Appropriateness	\$300.00
Road/Easement Vacation/Closure (review only)	\$350.00

Page 2 of 2 – Schedule of Fees and Charges

	<u>Fee</u>
Special Permit for land and water fills, dredging, excavation and mining	\$1,000.00
Special Permit to construct a bulkhead dock, pier, wharf or similar structure	\$500.00
Site & Development Plan Approval	\$3,500.00
Minor modification to an approved site plan	\$100.00
Special Temporary Use permit issued by the Board of County Commissioners	\$750.00
Borrow pit special permit issued by the Board of Adjustments	\$750.00
A Certificate of Land Development Regulation Compliance	\$75.00
Alcohol License Zoning Approval	\$75.00
Zoning or Flood Zone Letter	\$50.00
Development Permit (flood zone)	\$50.00
Certificate of Concurrency Compliance	\$100.00
Application for Vested Rights	\$500.00
Data, Analysis, & Concurrency Report	\$1,700.00
Attend a PZB/BCC Meeting	\$400.00
Single update to the FLUM/Zoning Atlas	\$420.00
Quarterly update to the FLUM/Zoning Atlas	\$700.00
Questions from County Staff/Public (Calls/Emails)	\$50.00

*Note: Fees do not include a Data, Analysis, & Concurrency Report or attending meetings. If a Data, Analysis, & Concurrency Report is desired or attendance at a meeting, the flat rate fees must be included with the cost associated with the application type.

BOARD OF COUNTY COMMISSIONERS OF BRADFORD COUNTY, FLORIDA

AGENDA ITEM INFORMATION SHEET

DATE: April 7, 2026

AGENDA ITEM Confirmation of Bernadette Fisher as Zoning Director

DEPARTMENT: Zoning

PURPOSE: Ms. Fisher is a planning professional with 15 years of progressive leadership experience in county and municipal planning, zoning administration, growth management, and private-sector real estate development. Please welcome her to the Bradford County team.

BOARD OF COUNTY COMMISSIONERS OF BRADFORD COUNTY, FLORIDA

AGENDA ITEM INFORMATION SHEET

DATE: April 7th, 2026

AGENDA ITEM: Disbursement of \$6,093.41 of Federal Emergency Management Agency (FEMA) Public Assistance (PA) claim for Bradford County Public Works “cut & toss” operations during Hurricane Helene (DR-4828-FL).

DEPARTMENT: Emergency Management

PURPOSE: N/A

ASSOCIATED COST(S): N/A

BUDGET LINE (G/L #): N/A

PAYMENT DATE	PAYMENT NUMBER	PAYEE NAME	PAYMENT TYPE	AGENCY DOC.NBR.	INVOICE NUMBER	INVOICE AMOUNT
--------------	----------------	------------	--------------	-----------------	----------------	----------------

FOR ADDITIONAL INFORMATION PLEASE CONTACT: DEPARTMENT OF REVENUE AT (850) 617-8586

2026/03/02	0487489	BRADFORD COUNTY BOCC	REGULAR EFT	V002295	1	6,093.41
------------	---------	----------------------	-------------	---------	---	----------

FOR ADDITIONAL INFORMATION PLEASE CONTACT: EXECUTIVE OFFICE OF THE GOVERNOR AT (850) 815-4624

2026/03/03	0491873	BRADFORD COUNTY BOCC	REGULAR EFT	V010710	MH022526	72.00
------------	---------	----------------------	-------------	---------	----------	-------

FOR ADDITIONAL INFORMATION PLEASE CONTACT: DEPARTMENT OF HIGHWAY SAFETY AND MOTOR VEHICLES AT (850) 617-3301

2026/03/04	0494569	BRADFORD COUNTY BOCC	REGULAR EFT	VD60311	0226 Pari	55,812.50
------------	---------	----------------------	-------------	---------	-----------	-----------

FOR ADDITIONAL INFORMATION PLEASE CONTACT: DEPARTMENT OF REVENUE AT (850) 617-8586

2026/03/05	0497346	BRADFORD COUNTY BOCC	REGULAR EFT	V010227	MH021326	51.00
------------	---------	----------------------	-------------	---------	----------	-------

FOR ADDITIONAL INFORMATION PLEASE CONTACT: DEPARTMENT OF HIGHWAY SAFETY AND MOTOR VEHICLES AT (850) 617-3301

2026/03/05	0497601	BRADFORD COUNTY BOCC	REGULAR EFT	V010858	MH022726	105.00
------------	---------	----------------------	-------------	---------	----------	--------

FOR ADDITIONAL INFORMATION PLEASE CONTACT: DEPARTMENT OF HIGHWAY SAFETY AND MOTOR VEHICLES AT (850) 617-3301

2026/03/06	0651320	BRADFORD COUNTY BD OF COUNTY CO	REGULAR WARRANT	V006581	26042	2,629.80
------------	---------	---------------------------------	-----------------	---------	-------	----------

FOR ADDITIONAL INFORMATION PLEASE CONTACT: DEPARTMENT OF HEALTH AT (850) 245-4494

2026/03/10	0506737	BRADFORD COUNTY BOCC	REGULAR EFT	V011083	MH030426	82.75
------------	---------	----------------------	-------------	---------	----------	-------

BOARD OF COUNTY COMMISSIONERS OF BRADFORD COUNTY, FLORIDA

AGENDA ITEM INFORMATION SHEET

DATE: April 7, 2026

AGENDA ITEM A RESOLUTION OF THE BOARD OF COUNTY COMMISSIONERS OF BRADFORD COUNTY, FLORIDA, AUTHORIZING THE SUBMISSION OF AN APPLICATION FOR, AND THE ADMINISTRATION OF, A BOATING ACCESS GRANT FROM FLORIDA FISH AND WILDLIFE CONSERVATION COMMISSION FLORIDA BOATING IMPROVEMENT PROGRAM; PROVIDING DIRECTION TO STAFF AND PROVIDING AN EFFECTIVE DATE.

DEPARTMENT: County Manager

PURPOSE: This resolution authorizes the staff to submit a grant application to FWC for the construction of the Cypress Run Boat Ramp.

RESOLUTION 2026-_____

A RESOLUTION OF THE BOARD OF COUNTY COMMISSIONERS OF BRADFORD COUNTY, FLORIDA, AUTHORIZING THE SUBMISSION OF AN APPLICATION FOR, AND THE ADMINISTRATION OF, A BOATING ACCESS GRANT FROM FLORIDA FISH AND WILDLIFE CONSERVATION COMMISSION FLORIDA BOATING IMPROVEMENT PROGRAM; PROVIDING DIRECTION TO STAFF AND PROVIDING AN EFFECTIVE DATE.

WHEREAS, the Board of County Commissioners of Bradford County, Florida has determined that recreational boating and fishing is a viable industry that significantly contributes to economic growth; and

WHEREAS, the Board of County Commissioners of Bradford County, Florida desires to improve upon and expand facilities which will encourage recreational boating and fishing; and

WHEREAS, the Board of County Commissioners of Bradford County, Florida has determined that enhancing and redeveloping the boat ramp area on Lake Sampson in Bradford County, Florida – commonly known as Cypress Run Boat Ramp – will support and encourage recreational boating and fishing activities; and

WHEREAS, the State of Florida, Fish and Wildlife Conservation Commission administers the Florida Boating Improvement Program which provides grant funds for the redevelopment and improvement of boating and fishing access facilities; and

WHEREAS, the Board of County Commissioners of Bradford County, Florida desires to obtain funding from the State of Florida, Fish and Wildlife Conservation Commission to redevelop and improve the Cypress Run Boat Ramp; and

WHEREAS, the Board of County Commissioners of Bradford County, Florida finds that the redevelopment and improvement of the Cypress Run Boat Ramp and the securing of funds from the

State of Florida, Fish and Wildlife Conservation Commission for the same is in the best interest of Bradford County, Florida and its citizens.

NOW THEREFORE, BE IT RESOLVED by the Board of County Commissioners of Bradford County, Florida as follows:

Section 1. Adoption and Incorporation of Recitals.

The Board of County Commissioners of Bradford County, Florida adopts the above-outlines recitals and incorporates them herein as part and parcel of this resolution.

Section 2. Purpose and Authority of Resolution

- A. This resolution is adopted for the purpose of authorizing the submission of an application for, and the administration of, a boating access grant from the State of Florida, Fish and Wildlife Conservation Commission; and
- B. This resolution is adopted pursuant to the authority granted by Chapter 125, *Florida Statutes*, and all other applicable provision of Florida law.

Section 3. Finding and Declaration of Workability.

The Board of County Commissioners of Bradford County, Florida hereby finds and declares that the Florida Boating Improvement Program, administered by the State of Florida, Fish and Wildlife Conservation Commission, is a workable program for the provision of needed boating improvements – as indicated in the 2026 Florida Boating Improvement Grant Application for Boating Access Facilities.

Section 4. Direction to Staff.

- A. The Board of County Commissioners of Bradford County, Florida direct staff to complete and submit to the State of Florida, Fish and Wildlife Conservation Commission an application for a 2026 Boating Access Facilities Grant for the construction, redevelopment, and improvement of the Cypress Run Boat Ramp through the Florida Boating Improvement Program; and
- B. The Board of County Commissioners of Bradford County, Florida further directs staff to take any and all other steps necessary to effectuate the direction provided for elsewhere herein.

Section 5. Effective Date of Resolution.

This resolution shall be effective immediately upon adoption by the Board of County Commissioners of Bradford County, Florida.

RESOLVED AND ADOPTED by the Board of County Commissioners of Bradford County, Florida, with a quorum present and voting, this 7th day of April 2026.

BOARD OF COUNTY COMMISSIONERS OF
BRADFORD COUNTY, FLORIDA

By: CAROLYN SPOONER, as its
Chairwoman

ATTEST:

By: DENNY THOMSPON, as
Clerk to the Board

APPROVED AS TO LEGAL FORM:

By: ROB BRADLEY, as
County Attorney

BOARD OF COUNTY COMMISSIONERS OF BRADFORD COUNTY, FLORIDA

AGENDA ITEM INFORMATION SHEET

DATE: April 7, 2026

AGENDA ITEM: Utility Vehicle

DEPARTMENT: Bradford County TDC

PURPOSE/DESCRIPTION: Marketing and Promotion of Bradford County

ASSOCIATED COST(S): \$25,000.00

BUDGET LINE (G/L #): 111-54-526-64000-00 (\$10,000)
002-86-552-64000-00 (\$25,000)

AGENDA ITEM APPROVAL

DEPT. REPRESENTATIVE

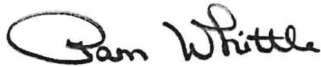

03/31/2026

SIGNATURE

DATE

COUNTY MANAGER

SIGNATURE

DATE



**Bradford County
Tourism Development Council**
100 East Call Street
Starke, FL 32091

Tuesday, March 31, 2026

"Our mission is to give tourists a reason to visit our region of Florida."

Amount Due: \$25,000.00

Amount Paid: \$ _____

Bradford County Tourism Development Council

Utility vehicle

Payable to:

Bradford County Fire and Rescue
Starke, FL 32091

Mail to:

Bradford County Fire and Rescue
Starke FL 32091

Contact:

Ben Carter

Bradford County Tourist Development Council

Minutes

March 19, 2025

12:00 Noon

Beef O Brady's
Starke, FL

Board Members Present: John Miller, Danny Riddick, Andy Redding, Gene Melvin, Vincent Esson, Chuck Kramer, Dale Woodruff, Steve Futch arrived late (8)

On the phone: (0)

Board Members Absent: Paula Register

Chamber Staff Present: Pam Whittle

Guests: Ben Carter, Tia Jackson, Chrissy Thompson, Scott Kornegay

Chair Miller, opened the meeting at 12:10

Approval of the minutes from the February meeting, a motion to approve the minutes was made by Dale Woodruff the motion was second by Andy Redding, motion passed 7-0.

Financial Report was accepted motion to accept was made by Dale Woodruff the motion was second by Vincent Esson the motion passed 7-0.

The board was presented with 3 quotes to repair the 5 entrance doors at the conference center. The board reviewed the bids knowing that there would likely be extensive damage that would go beyond just the doors themselves. These repairs would be needed to make sure all codes were met. Dale Woodruff made a motion to go with H. D. Starlings Custom Builders in the amount of \$25,600.00 to replace the front doors and the 4 individual doors, knowing that the bid may have to be increased to include repairs to meet code, his motion was second by Vincent Esson, the motion passed 7 – 0.

The Clear Channel billboard north of town, contract is due for renewal, the amount is \$9555 annually with a \$250 to change the vinyl. Andy Redding made a motion to renew the contract for another year and refresh the vinyl as well. His motion was second by Vincent Esson, the motion passed 8 – 0 as Steve Futch had joined the meeting at this time.

The billboard advertising Bradford County on the south end of town is also due for renewal it is located in the Hampton area. Steve Futch made the motion to renew at the price of \$7200 annually and to leave that vinyl as it is still in good condition. His motion was second by Dale Woodruff and the motion passed 8 – 0.

REPORTS and INFORMATIONAL ITEMS –

Ben Carter attended the meeting and wanted to present to the board the possibility of adding a new quick response vehicle to maneuver through smaller areas during festivals, events, fairs and sports events primarily to keep visitors safe as we increase attendance and add more of these kinds of activities in the county. This would allow us to show our out-of-town folks that they are safe when coming to our county and encourage others to utilize the facilities we have to offer here. This would be a pro active action not a reaction to a bad situation that could occur.

The board discussed the many uses of this utility vehicle and how this was to be in addition to larger units that we have currently. After much discussion, the board wanted to consider the request not to exceed \$35,000.

At 1:00 Andy Redding moved to adjourn his motion was second by Steve Futch.

The Chairman called the meeting back to order after receiving a donation of \$10,000 toward the project, Dale Woodruff made a motion to provide an amount not to exceed \$25,000 for the purchase and retrofitting of the utility vehicle, his motion was second by Danny Riddick, the motion passed 6 -0. Paula Register out of town, Andy and Chuck were unable to attend.

Minutes prepared by Pam Whittle, IOM President / CEO



Tuesday, March 31, 2026

Scott Kornegay
Bradford County Manager's Office
PO Drawer B
Starke, FL 32091

At the Bradford County TDC meeting held March 19, 2026 the TDC board voted to approve the following expenditures:

The TDC board voted to approve an expenditure of \$25,000 to aid in the purchase of a quick response utility vehicle to assist in protection of crowd and visitors during special events, festivals, fairs, and sports events.

Would you please place this item on the agenda for approval by the Bradford County Commission.

I have attached AII sheets, invoices with address, and the minutes from the March meeting approving the expenditure.

If there are any questions I may be reached at the Chamber office by calling 904-964-5278, or by cell 904-364-7051.

Thank you for your cooperation.

Sincerely,

A handwritten signature in black ink that reads 'Pam Whittle'.

Pam Whittle, IOM
President / CEO
North Florida Regional Chamber of Commerce

BradfordCountyFloridaTourism.com

Chairman. John Miller Board Members; Danny Riddick, Vincent Esson, Steve Futch, Chuck Kramer,
Paula Register, Andy Redding, Dale Woodruff, Gene Melvin

BOARD OF COUNTY COMMISSIONERS OF BRADFORD COUNTY, FLORIDA

TELEPHONE QUOTE DOCUMENTATION FORM

Instructions: For all purchases in between \$1,001.00 and \$5,000.00, three (3) quotes must be obtained. For each verbal or telephone quote, obtain the information below then submit this form to the County Manager for approval.

This form must also be submitted to the Finance Department.

Department: Bradford County Fire Rescue
Contact Person: Cody Johnson
Item or Project: Polaris Ranger
G/L or Budget Line: 002-86-552-64000-00 and 111-54-526-64000-00

QUOTE 1

Vendor: Holeshot Powersports
Date: 3/31/26 Time: _____
Contact: Rick Position: _____
Quote Amount: 21,887.25

Notes: Preferred

Approved: Approved contingent on BOCC approval of TDC funding. Date: 3-31-26

County Manager (or Designee) Signature: [Signature]

QUOTE 2

Vendor: ST. Johns Powersports
Date: 3/26/26 Time: _____
Contact: Brandon Position: _____
Quote Amount: 21896.50
Notes: _____

Approved: _____ Date: _____

Requisition Number: _____

County Manager (or Designee) Signature: _____

QUOTE 3

Vendor: McDuffie Marine and sporting goods
Date: 3/26/26 Time: _____
Contact: _____ Position: _____
Quote Amount: 22,249.00
Notes: _____

Approved: _____ Date: _____

Requisition Number: _____

County Manager (or Designee) Signature: _____



6945 US Hwy 17- Fleming Island, FL 32003
(904)863-3131/ (904)863-3152 Fax

BILL OF SALE

Date 03/31/2026
Deal # 6850

Buyer-BRADFORD COUNTY FIRE RESCUE SERVICE **Co-Buyer-**
945-C NORTH TEMPLE AVENUE
Starke, FL 32091
904-966-6911 ben_carter@bradfordcountyfl.gov

Major Unit-

Stock#	Year	Make	Model	VIN#	License#	Mileage
POL000403	2026	Polaris	ar Crew XP 1000 Pre	4XARSE992T8000403	R26RSE99AH	0

LienHolder:

Trade-In-

Stock#	Year	Make	Model	VIN#	License#	Mileage
--------	------	------	-------	------	----------	---------

- 1)
- 2)

Payoff To: 1)
 2)

Vehicle Price	\$20,543.00
Freight	\$1,299.00
Set-up	\$0.00
*Dealer Fee	\$0.00
Trade-In	\$0.00
Subtotal	\$21,842.00

*Dealer Fee represents costs and profit to the dealer for items such as inspecting, cleaning and adjusting new and used vehicles and preparing documents related to the sale.

Parts & Accessories	\$0.00
Labor	\$0.00
Tire/Battery Fee	\$5.50
Tag, Title, Registration and Other Fee	\$39.75
Months _____ Extended Service Contract	\$0.00
Pre-Paid Maintenance	\$0.00
Appearance Protection	\$0.00
Tire & Wheel	\$0.00
Theft Protection	\$0.00
GAP	\$0.00
Subtotal	\$21,887.25

Customer acknowledges they were offered Extended Service, PrePaid Maintenance, Appearance Protection, Tire & Wheel Protection, Theft Protection, and GAP. Customer has DECLINED protection unless purchased as shown on this Bill of Sale.

(_____) (_____) **Customer Initials**

Buyer: _____ Date: ____/____/____ Co-
Buyer: _____ Date: ____/____/____
Dealer: _____ Date: ____/____/____

preferred

Trade-In Payoff	\$0.00
Doc Stamp	
Total Sales Tax	\$0.00
Rebate	\$0.00
Down Payment	\$0.00
Balance Due	\$21,887.25

In signing this Bill of Sale, Customer acknowledges that the above purchased item(s) were paid for by cash, check, credit card, or a fundable finance contract. All Sales are final. No refunds on above product, unless stated in writing otherwise. Dealer retains all incentives unless otherwise stated on this Bill of Sale.

Buyer: _____ Date: _____ 03/31/2026
Co-Buyer: _____ Date: _____ 03/31/2026
Dealer: _____ Date: _____ 03/31/2026

BOARD OF COUNTY COMMISSIONERS OF BRADFORD COUNTY, FLORIDA

AGENDA ITEM INFORMATION SHEET

DATE: April 7, 2026

AGENDA ITEM First Amendment to the MOU between the Florida Department of Health and Bradford County for the continued clerical staff support for the Onsite Sewage Wastewater Treatment Disposal Program (OSTDS)

DEPARTMENT: BOCC

PURPOSE: This amendment will extend the agreement for three years with an additional 1 year extension following. The original MOU is attached following the proposed amendment.

ASSOCIATED REVENUE: \$10,000 Annually

BUDGET LINE (G/L #):

**FIRST AMENDMENT TO THE
MEMORANDUM OF UNDERSTANDING
between
The Florida Department of Health and Bradford County**

This Amendment to the Memorandum of Understanding (“AMOU”) between: Bradford County, Florida through its Board of County Commissioners (“County”); and the Florida Department of Health (“DOH”) (collectively “Parties”), confirms the Parties’ intent to continue to support DOH’s Environmental Health staff through clerical support for the Onsite Sewage Wastewater Treatment Disposal Program (“OSTDS”) relating to Bradford County.

WHEREAS, the Parties entered into a Memorandum of Understanding on March 7, 2023; and

WHEREAS, the Parties wish to continue and extend the Memorandum of Understanding under the same terms and conditions.

NOW, THEREFORE, the Parties enter into this AMOU, for the benefit of both Parties, the sufficiency of which is acknowledged by the Parties, and as follows:

1. The above stated recitals are true and correct and incorporated fully into this AMOU.
2. Paragraph 4. of the Memorandum of Understanding is amended to state: “This MOU will remain in effect for three (3) years beginning April 1, 2026 or upon completion of the transition of these tasks to the Florida Department of Environmental Protection (“DEP”), whichever is sooner, unless or until the MOU is terminated by either Party. Upon expiration of the current term, the parties may extend this MOU in one (1) year additional terms upon mutual agreement of the parties.”
3. The remaining terms and conditions of the Memorandum of Understanding dated March 7, 2023 shall remain in full force and effect.

[The remainder of this page is left blank intentionally]

IN WITNESS WHEREOF, the Parties agree and accept this MOU on this _____ day of April 2026.

BRADFORD COUNTY, FLORIDA
BOARD OF COUNTY COMMISSIONERS:

By: _____
Carolyn Spooner, Chair

ATTEST:

Denny Thompson, Clerk of Court

FLORIDA DEPARTMENT OF HEALTH

By: _____
Amie G. Oody, Administrator
Bradford County Health Department

Witness:

Print Name

Witness:

Print Name

Original MOU

MEMORANDUM OF UNDERSTANDING
between
The Florida Department of Health and Bradford County

This Memorandum of Understanding ("MOU") between: Bradford County, Florida through its Board of County Commissioners ("County"); and the Florida Department of Health ("DOH") (collectively "Parties"), confirms the Parties' intent to support DOH's Environmental Health staff through clerical support for the Onsite Sewage Wastewater Treatment Disposal Program ("OSTDS") relating to Bradford County.

WHEREAS, the County has been advised of delays in the processing of OSTDS Construction Applications; and

WHEREAS, the Environmental Health Director for DOH is able to utilize clerical staff support to reduce the processing times of OSTDS Construction Applications; and

WHEREAS, the County and DOH wish to enter into this MOU in order to outline the terms and expectations of using Bradford County staff to assist the Environmental Health Director.

NOW, THEREFORE, the Parties enter into this MOU, for the benefit of both Parties, the sufficiency of which is acknowledged by the Parties, and as follows:

1. The above stated recitals are true and correct and incorporated fully into this MOU.
2. The County agrees to provide a part-time employee for up to ten (10) hours a week to DOH in order to provide clerical support related to OSTDS Construction Applications. The expectations for the position are outlined in the Position Description, attached as Exhibit A.
3. The DOH agrees to reimburse the County \$10,000 per year for the costs related to the clerical support provided under this MOU. This amount will increase by five percent (5%) in Year 2 and again in Year 3. Payments from DOH to the County will be made in equal monthly installments on or before the fifth day of each calendar month.
4. This MOU will remain in effect for three (3) years or upon completion of the transition of these tasks to the Florida Department of Environmental Protection ("DEP"), whichever is sooner, unless or until the MOU is terminated by either Party.
5. Termination of this MOU may occur with or without cause after either party provides written, thirty (30) days' notice to the other party of the intent to terminate this MOU.
6. The parties shall indemnify and save harmless and defend each other, its agents, servants and employees from and against any and all claims, liability, losses, and/or causes of action which may arise from any act or omission of its agents, servants, or employees, or which otherwise arises in connection with, the performance of this MOU.

7. The County and DOH understands that by virtue of this MOU, all of its documents, records, and materials of any kind, relating to the relationship created hereby, shall be open to the public for inspection in accordance with Florida law.

IF EITHER PARTY HAS QUESTIONS REGARDING THE APPLICATION OF CHAPTER 119, FLORIDA STATUTES, TO THE DUTY TO PROVIDE PUBLIC RECORDS RELATING TO THIS MOU, CONTACT THE CUSTODIAN OF PUBLIC RECORDS AT: BRADFORD COUNTY, 904-966-6327, 945 NORTH TEMPLE AVENUE, STARKE, FLORIDA 32091.

8. The County and DOH expressly retain all rights, benefits, and immunities of sovereign immunity in accordance with Section 768.28, Florida Statutes. Notwithstanding anything set forth in any section, article or paragraph to the contrary, nothing in this MOU shall be deemed as a waiver of sovereign immunity or limits of liability which may have been adopted by the Florida Legislature or may be adopted by the Florida Legislature, and the cap on the amount and liability of the County for damages, attorney fees and costs, regardless of the number or nature of claims in tort, equity or contracts, shall not exceed the dollar amount set by the Florida Legislature for tort. Nothing in this MOU shall inure to the benefit of any third party for the purpose of allowing any claim against the County which would otherwise be barred under the Doctrine of Sovereign Immunity or operation of law.
9. Each notice or communication under this MOU shall be deemed delivered and received if in writing and either: (a) personally delivered; (b) delivered by reliable overnight courier service; (c) deposited with the United States Postal Service or any official successor thereto, certified or registered mail, return receipt requested, with adequate postage prepaid, delivered or addressed to DOH or the County, as appropriate; or d) sent by email transmission providing proof of transmission. Rejection or other refusal by the addressee to accept the notice, and inability to deliver the notice because of a change of address of the party of which no notice was given, shall be deemed to be the receipt of the notice on the third (3rd) day following the date postmarked by the United States Postal Service, or on the second (2nd) day following the date accepted by the courier service. Notice shall be made to the following addresses:

Bradford County, Florida
945 North Temple Avenue
Starke, Florida 32091

Florida Department of Health
North Central Consortium Legal Office
224 SE 24th Street
Gainesville, Florida 32641

10. This MOU shall be governed by, and construed in accordance with, the laws of the State of Florida, specifically the courts of original jurisdiction in Bradford County, Florida.
11. The Parties acknowledge and understand that they have a duty to and will cooperate with the Inspector General in any investigation, audit, inspection, review, or hearing pursuant to Section 20.055(5), Florida Statutes.

Exhibit A

Position Description:

This is a professional clerical support position assisting the Environmental Health Director and Environmental Health staff in the Onsite Sewage Wastewater Treatment Disposal Program (OSTDS) in Bradford County. The work of this position involves specific objectives and content and requires independent decision making and solutions by operating within established policies, laws, rules, and guidelines.

Receives telephone calls and emails and routes messages to Environmental Health staff or transfers calls to appropriate OSTDS staff immediately.

Enters and processes completed OSTDS Construction Application data into the Environmental Health Data Base (EHD) within one (1) business day. Creates OSTDS labeled file with all submitted documentation to be used by inspector in the field within two (2) business days.

Conducts 811 "call-before-you-dig" line locate for construction permits as necessary for non-private evaluator applications within one (1) business day.

Enters and processes completed Private Provider Inspection Data into EHD within two (2) business days and notifies EH Staff that Construction Final is ready for review.

Processes OSTDS fees and generates invoices and receipts in EHD and provides to the client immediately for in-person transactions or within two (2) business days for online/electronic transactions.

Maintains and schedules OSTDS inspection appointments and places the appointments into the appropriate Inspection Log daily as calls come in.

Deliverables:

Completed and processed OSTDS Construction Applications entered into EHD with verifiable generated state permit number and including proper fees collected and supporting documentation.

Completed and labeled permit files with all supporting documentation for all applications received.

Completed weekly Inspection Schedule log.

BCHD will provide:

EH Workstation consisting of all necessary peripherals including an EH laptop.

Access to all necessary Applications including EHD.

Training necessary for all Applications including EHD.

12. This MOU constitutes the entire understanding and agreement of the Parties with respect to its subject matter.

IN WITNESS WHEREOF, the Parties agree and accept this MOU on this 7th day of March, 2023.

BRADFORD COUNTY, FLORIDA
BOARD OF COUNTY COMMISSIONERS:

By: 
Diane Andrews, Chair

ATTEST:

Denny Thompson, Clerk of Courts

Florida Department of Health

By: 
Amie G. Oody, Administrator
Bradford County Health Department

Witness:

SSKORNEGAY
Print Name

Witness:

Jason Dodds
Print Name

BOARD OF COUNTY COMMISSIONERS OF BRADFORD COUNTY, FLORIDA

AGENDA ITEM INFORMATION SHEET

DATE: April 7, 2026

AGENDA ITEM Proclamation Declaring April 2026 as “Child Abuse Prevention Month”.

DEPARTMENT: County Manager

PURPOSE: A proclamation declaring April 2026 as “Child Abuse Prevention Month”, presented by Amanda Demaria, Director of Development and Engagement for Partnership for Strong Families.

ASSOCIATED COST(S):

BUDGET LINE (G/L #):

BOARD OF COUNTY COMMISSIONERS OF BRADFORD COUNTY, FLORIDA

PROCLAMATION DECLARING APRIL 2026 AS

“CHILD ABUSE PREVENTION MONTH”

WHEREAS, Prevention is possible. With the right policies and investments, families and children can thrive and avoid contact with child welfare; and

WHEREAS, every family and child is filled with tremendous promise, and we all have a collective responsibility to prevent child abuse, foster the potential of every child, and promote a positive childhood; and

WHEREAS, families who receive the support they need before a crisis occurs are better equipped to provide safe, healthy, and nurturing environments, leading to children who are safer, healthier, and more hopeful about their futures; and

WHEREAS, childhood trauma, including abuse and neglect, can have long-term psychological, emotional, and physical effects throughout an individual's lifetime and impact future generations; and

WHEREAS, effective child abuse prevention activities succeed because of the partnerships created between child welfare professionals, education, health, community- and faith-based organizations, businesses, law enforcement agencies, and families; and

WHEREAS, communities must make every effort to promote programs and activities that create strong and thriving children and families; and

WHEREAS, we acknowledge that we must work together as a community to increase awareness about child abuse and contribute to promoting the social and emotional well-being of children and families in a safe, stable, and nurturing environment; and

WHEREAS, prevention remains the best defense for our children and families.

NOW, THEREFORE, I, Board Chair of the Bradford County Board of County Commissioners do hereby proclaim April 2026 as CHILD ABUSE PREVENTION MONTH in Bradford County and urge all citizens to recognize this month by dedicating ourselves to the task of improving the quality of life for all children and families. Together, we can create a community where every child can grow up happy, healthy, and safe with hope for their future.

Carolyn Spooner, Chair

BOARD OF COUNTY COMMISSIONERS OF BRADFORD COUNTY, FLORIDA

AGENDA ITEM INFORMATION SHEET

DATE: April 7, 2026

AGENDA ITEM Presentation - Clay County Commissioner, Betsy Condon

DEPARTMENT: BoCC

PURPOSE: Lake Geneva Project

ASSOCIATED COST(S):

BUDGET LINE (G/L #):

BOARD OF COUNTY COMMISSIONERS OF BRADFORD COUNTY, FLORIDA

AGENDA ITEM INFORMATION SHEET

DATE: 03/25/2026

AGENDA ITEM: AIR BURNERS, INC.

DEPARTMENT: PUBLIC WORKS/SOLID WASTE DEPARTMENT

PURPOSE: This will lower cost of hauling limbs debris from the Keystone Collection Site to New River Landfill. I have included a cost breakdown on a separate page.

ASSOCIATED COST(S): \$213,862.53 / This would be a Sole Source and the GSA State contract #47QMCA20D004T

BUDGET LINE (G/L): 113-65-534-64000-00

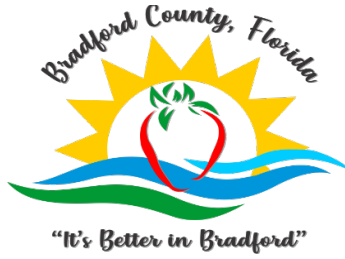

Bradford County Public Works

Department of Solid Waste and Mosquito Control

Bennie L. Jackson Jr., Director
bennie_jackson@bradfordcountyfl.gov

03/25/2026

Good morning, Chairwoman and Commissioners,

Mr. Dodds and I have been in discussions about an Air Burner for the Keystone Collection Site for the Limb Debris that we currently haul to New River Landfill. We currently have 2 Employees that are responsible for Loading and Hauling this debris. The Cost of the employee's as it is, is \$4,024.00 a month. Also, the cost of fuel for a month hauling is \$2,012.00. This does not include the maintenance on the Trucks that are hauling this debris that could be another \$800.00 for tire maintenance. There is also a tonnage fee of \$44.00 a Ton if it is oversized and will not fit into their grinding machine. This cost can be \$1,100.00 a month. The year Total is: \$95,232.00. If the Solid Waste Director can cut this operational cost to have 1 employee and that employee will operate the equipment to load the Air Burner and will reduce the debris to ash. The only cost is 1 Employee: \$2,000.00 a month or less, because we would not have to burn every day. The fuel cost would be: \$280.00 a month. Maintenance would be reduced because we would not be running the Truck to New River Landfill just to Haul Limb Debris. Total Cost a Year with the Air Burner would be: \$33,360.00. **This is Savings of: \$61,872.00.** I have included a packet of the Air Burner and what it looks like and what it does. This would be very beneficial for Hurricane and any other storm related events. We could place this equipment in any location that would be needed. I will be changing the CIP for this year, taking the \$300,000.00 Grapple Truck off and replacing it with the Air Burner, that costs \$213,862.00. **Saving on this 25–26-year CIP of \$86,138.00.**

Thank you,

Solid Waste Director, Bennie L. Jackson Jr.

Date



Proforma Invoice

AIR BURNERS, INC.
 4390 SW Cargo Way
 Palm City, FL 34990 USA
 Phone 772-220-7303
www.AirBurners.com

DATE 23-Mar-2026
Our Reference # S223732247

Email : akuypers@airburners.com
Mobile Phone: 772-274-2515

GSA Contract # 47QMCA20D004T

Bill To:
 Bradford County
 TBD

Ship To:
 Bradford County
 TBD

Phone	Jason Dodds 352-745-4038
Email	jason_dodds@bradfordcountyfl.gov

FOB POINT	SHIP DATE ARO	SHIP VIA	PAYMENT TERMS
Palm City, FL	6-8 weeks	Truck	See Note 1

ITEM	QUANTITY	DESCRIPTION	P/N	UNIT PRICE \$	AMOUNT \$
1	1	Air Burners 2026 Model S223 FireBox Four-cylinder 74 hp Turbo Diesel Engine, Does not require DEF; Emissions certified U.S. EPA Tier 4F; Engine mounted fluid coupling (automatic clutch)	S223	\$ 195,017.53	\$ 195,017.53
2	1	S223 Ash Rake (Optional - See Note 2)	5000-2367	\$ 9,850.00	\$ 9,850.00
3	1	Starter Kit with In-Person Operator Training and Certification (Optional)	5000-2991	\$ 8,995.00	\$ 8,995.00
4	LOT	Estimated Shipping Charges (See Note 4)	Shipping	included	\$ -

TOTAL DUE \$ 213,862.53

NOTES:

- Note 1** Payment Terms: Government Terms, Net 30 Days after receiving FireBox.
- Note 2** The machines will be shipped as standard load on a Common Carrier Truck. Unloading cost, if any, at destination is not included in Line Item 4 and is to the account of Buyer.
- Note 3** The optional ash rake implement with universal quick disconnect face-plate for Skidsteer, Bobcat, etc. will travel inside the FireBox.
- Note 4** The prices stated in this Quotation are valid for 30 days.
- Note 5** The published specifications for the machines apply. Please, see www.airburners.com
 Starter pack includes (1) Onsite training certification course, (1) PM service pack, (1) Thermal ceramic patch compound, (1) Lighting torch. Virtual training is also available at \$3,995. Please see also:
<https://airburners.com/support/operator-training-and-certification/>

We thank you for the opportunity to be of service!

Alexis Kuypers
 Account Manager



Operating Manual

200 SERIES

S220 & S223

Equipped With HATZ 4H50-TIC Diesel Engine and Fluid Coupling
(3H50-TIC Optional)
Engine U.S. EPA Tier 4F Certified

Self-Contained Refractory Walled Air Curtain Burner

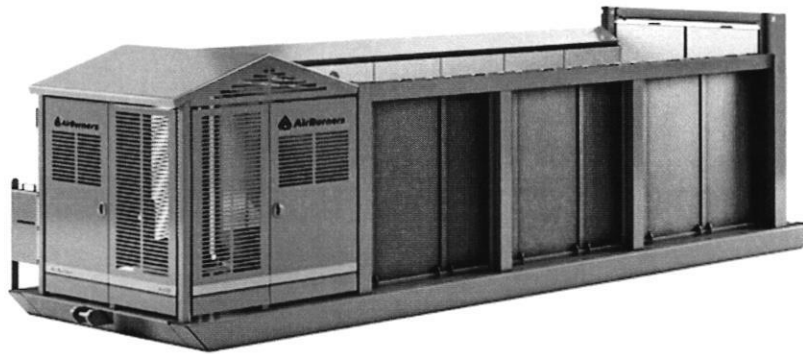

“Better Economically - Better Environmentally”

MADE IN THE USA

Factory and Main Office

Air Burners, Inc.
4390 SW Cargo Way
Palm City, FL 34990

Phone: 772-220-7303
888-566-3900
E-mail: support@airburners.com

Visit Our Website at
AirBurners.com



© 2025 Air Burners, Inc. All Rights Reserved.
Subject to change without notice. Dimensions & metric conversions rounded. The words *Air Burners*, *BurnBoss*, *CharBoss*, *TrackBoss*, *BioCharger* and the *Air Burners Logos* are Registered Trademarks of Air Burners, Inc.

(Vers. Jan. 07, 2025)

WARNING

Should any repairs become necessary that require welding on your FireBox, you **MUST** first physically remove the Electronic Control Module (ECM) from the computer controlled Diesel Engine (Applies to both 3H50 and 4H50). Follow the instructions below.

ECM Removal Steps

1. Wear Personal Protective Equipment (PPE).
2. Ensure engine is switched off and cold.
3. Disconnect negative battery cable.
4. Unsnap Latches 1 and 2.
5. Remove Bolts A1 and A2.
6. Unplug both connectors.
7. Remove Bolts B1, B2, B3 and B4.
8. Remove the two brackets.
9. The ECM can now be removed and stored away while repairs are made.
10. Re-install all in reverse order.



PERSONAL PROTECTIVE EQUIPMENT (PPE) & WOOD ASH CAUTION:

Always wear appropriate Personal Protective Equipment (PPE) while working with the FireBox, especially a breathing apparatus like a respirator while removing wood ash from the firebox (burn chamber) and while handling the wood ash. See also Page 7.

WARNING:

Please, read and understand all Caution and Warning Notices and Operating Instructions before working with the FireBox and always follow them diligently. Disregarding these important Notices may lead to an accident that may result in property damage, serious personal injury, or death.

Contact Air Burners, Inc. Customer Service should you require any assistance. Send Email to support@airburners.com, call 772-220-7303 or 888-566-3900.

INDEX

WELDING REPAIR WARNING	Page i
WARNINGS.....	Page iii
PRINCIPLE OF AIR CURTAIN INCINERATION	Page 1
GENERAL DESCRIPTION OF S-SERIES	Page 2
SAFETY CONSIDERATIONS	Page 5
HOW TO SET UP THE MACHINE	Page 8
SITE PREPARATION	Page 13
LOADING AND STARTING THE FIREBOX	Page 14
HOW TO FEED A FIRE	Page 18
SHUTDOWN	Page 19
ASH REMOVAL	Page 20
TROUBLESHOOTING	Page 22
MAINTENANCE AND CARE	Page 23
SERVICING SPECIFICATIONS	Page 25
LIFTING POINTS	Page 26
CHECKING COUPLING ALIGNMENT	Appendix A
HATZ ENGINE OVERVIEW (COMPONENT IDENTIFICATION)	Appendix B



200 Series Air Curtain Burner with HATZ 4H50 or 3H50 Diesel Engine & Fluid Coupling
OPERATING MANUAL

**PERSONAL PROTECTIVE EQUIPMENT (PPE)
& WOOD ASH CAUTION:**

Always wear appropriate Personal Protective Equipment (PPE) while working with the FireBox, especially a breathing apparatus like a respirator while removing wood ash from the firebox (burn chamber) and while handling the wood ash. See also Page 7.

WARNING:

PINCH POINT HAZARDS

Be mindful of Pinch Point Hazards. Keep your hands clear from all moving parts and hot parts of the FireBox while it is being set up or in operation.

IMPORTANT WARNING ABOUT THE BURNING OF PALLETS:

Wooden Pallets, especially spent pallets, burn extremely hot. DO NOT load the FireBox above approximately 3/4 of the height of the burn chamber. Heat damage to the manifold and other structure may occur which would not be covered under your Limited Factory Warranty.

CUSTOMER SUPPORT:

Contact Customer Support at Air Burners, Inc., should you require assistance with any maintenance task or should you have any questions regarding the setup or operation of your FireBox.

Email: support@airburners.com Phone: 772-220-7303 or 888-566-3900

**200 Series Air Curtain Burner with HATZ 4H50 or 3H50 Diesel Engine & Fluid Coupling
OPERATING MANUAL**



S220



S220

PRINCIPLE OF AIR CURTAIN INCINERATION

OPERATION

Air curtain incinerators (also called air curtain burner or FireBox) are designed primarily as a pollution control device. Using a Diesel Engine driven fan, these machines generate a curtain of air with a very particular mass flow and velocity. This curtain of air acts as a trap over the top of an earthen trench or thermal-ceramic lined firebox (burn chamber). The wood debris is dumped into the trench or firebox and then ignited (usually with a propane torch or with a small amount of diesel fuel where permitted) just as you would light any other pile of wood you intended to burn. Once the fire has gained strength the air curtain is turned on.

The air curtain traps most of the smoke particles and causes them to re-burn directly under the air curtain where the temperatures can exceed 1800° F (≈1000° C). These machines do not inject any fuels into the fire, the fire is sustained only by adding more wood feedstock. The air from the air curtain is not heated. The only fuel used in the continuous operation is that for the Diesel Engine that powers the air fan.

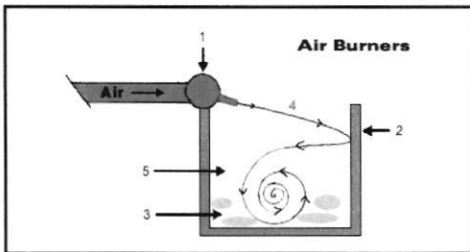

[Click Here](#) or Scan
for Video
"Open Pile Burning
vs FireBox Burning"

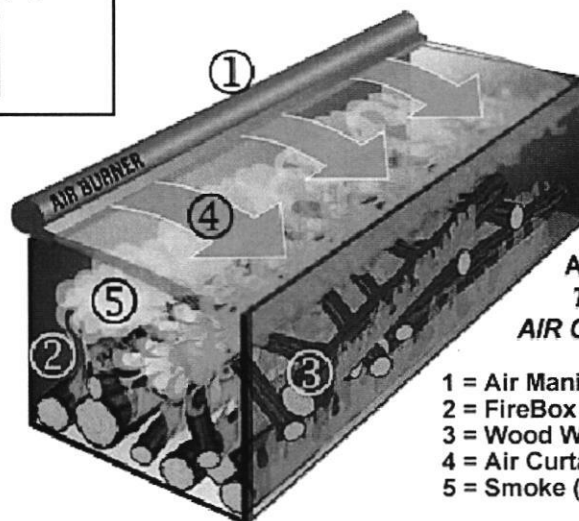

AIR BURNERS, INC.
THE PRINCIPLE OF
AIR CURTAIN BURNING

- 1 = Air Manifold
- 2 = FireBox Refractory Wall
- 3 = Wood Waste or Wood Fuel
- 4 = Air Curtain (left to right)
- 5 = Smoke (PM or Black Carbon)



**200 Series Air Curtain Burner with HATZ 4H50 or 3H50 Diesel Engine & Fluid Coupling
OPERATING MANUAL**

GENERAL DESCRIPTION S-SERIES

The self-contained refractory walled air curtain system is manufactured as an over-the-road transportable combustion system designed to reduce clean wood waste and vegetative growth to ash in a safe, controlled burning process without excessive particulate emissions. The FireBox is open to the ground (soil surface), except for the Roll-off versions; they have a floor to accommodate the roll-off rail system. The standard S-Series machines are offered in several sizes. The smallest is the S116 (16 ft. firebox) and the largest is the S330 (30 ft. firebox).

The T26 CharBoss is a trailer-mounted street-legal Biochar processor designed do optimize production of high-grade Biochar. The self-propelled T28 TrackBoss is similar to the T24 BurnBoss, however, with the trailer frame replaced by a remotely controlled track system.

Above-Ground Air Curtain Burner Dimensions					
Model	Overall Size L x W x H	Firebox L x W x H	Weight lbs.	Fuel gal/hr.	Average Thru-put* tons/hr.
S330	40' 4" x 11' 10" x 9' 6"	30' 2" x 8' 5" x 8' 1"	59,000	3.0	11-13
S327	37' 4" x 11' 10" x 9' 6"	27' 2" x 8' 5" x 8' 1"	54,600	3.0	9-11
S223	33' 3" x 8' 6" x 8' 6"	22' 11" x 6' 2" x 7' 1"	40,250	2.0	7-9
S220	30' 1" x 8' 6" x 8' 6"	19' 8" x 6' 2" x 7' 1"	36,650	2.0	5-7
S119	27' 3" x 7' 2" x 7' 4"	19 x 5' x 6'	30,100	1.9	3-5
S119R**	27' 6" x 7' 2" x 8' 3"	19 x 5' x 6'	39,900	1.9	3-5
S116	24' 7" x 7' 2" x 7' 4"	16' x 5' x 6'	27,500	1.9	2-4
S116R**	24' 11" x 7' 2" x 8' 3"	16' x 5' x 6'	36,300	1.9	2-4
T28	17' 10" x 8' 5" x 5' 8"	12' x 4' x 4'	15,350	1.1	½-1
T26	21' 8" x 7' 8" x 6' 8"	12' x 4' x 4'	17,500	1.1	½-1
T24	19' 8" x 7' 8" x 5' 8"	12' x 4' x 4'	9,980	0.56	½-1

* Approximate values. Achievable through-put depends on nature of waste stream and other factors.

** Cable-hoist version; Hook-lift version is 5" shorter with 54 gal. min. capacity fuel tank.

- FireBox** S330 & S327: HATZ 4H50TIC (Tier 4 Final) or equivalent engine.
- Diesel Engine Version:** S223, S220, S119, S119R, S116 & S116R: Tier 4F HATZ 4H50TIC or optionally HATZ 3H50TIC or equivalent engine.
- Drive System:** Fluid Coupling (Automatic Clutch) & mechanical direct coupling drive. Manual PTO as option.
- Electric Motor Version:** Motor: 3-Phase, heavy-duty, with enclosed pre-programmed variable frequency speed controller (VFD); Power in: Three Phase 480V, 50Hz or 60Hz, or selected other voltages, i.e. 415V or 400V; Drive System: Direct drive.
- Options:** Ash clean-out rake - price will be quoted for plain faceplate (S300) or universal quick disconnect (S200 & S100).
- Fuel Consumption:** Indicated fuel consumption rates approximated.
- Through-Put:** Through-put depends on many factors, such as nature and type of wood waste, its moisture content, prescribed opacity limits, operator skills, elevation of location, etc. The figures stated here are guidelines only. If more specific information is required, please contact the Customer Support.
- NOTES:** All weights and dimension are approximate. Dimensional drawings can be provided on request. Subject to change without notice.



200 Series Air Curtain Burner with HATZ 4H50 or 3H50 Diesel Engine & Fluid Coupling OPERATING MANUAL

GENERAL DESCRIPTION S-SERIES

When delivered to a job site, the S-Series machine is ready for use as soon as it is off-loaded. The entire system is built on a skid type base frame which is designed for easy movement over the earthen ground. The forward equipment deck supports a Diesel Engine, a fuel tank, the direct drive system and the air fan. When viewed from the front of the unit, the patented air disbursement manifold is mounted on the left top side of the firebox (combustion chamber). The firebox is lined with proprietary thermal-ceramic refractory panels. The panels are cured prior to installation at the factory to drive out any moisture to ensure they are stable at first use in the field. The back of the firebox is fitted with refractory lined doors that allow ash removal and access to the firebox (only when it is completely empty).

The Diesel Engine is coupled through a fluid drive (automatic clutch) that turns the air fan. The high velocity air is sent down the manifold through the vanes and directed to the outlet nozzles. A balanced and distributed air flow is directed across the top of the firebox (burn chamber) and then reflected down into the combustion zone.

The curtain of air acts as a lid over the firebox (burn chamber) trapping a large percentage of the escaping particulate matter (smoke or "Black Carbon") and causing it to burn down even further in the hot zone immediately below the curtain before finally escaping through the curtain visible as a hot gas. The air from the nozzles travels across the firebox creating the air curtain effect, then it reflects off the far side thermal-ceramic wall, adding oxygen to the combustion zone helping to generate a hotter more complete fire. This additional agitation helps prevent the fire from starving for oxygen as the ash builds up during burning operations.

NOTICE:

All of this is carefully engineered to provide the correct amount of air at the correct velocity. It is sometimes thought that more air flow will actually increase the burn rate. This is **INCORRECT**. Modifying the air flow will actually have the opposite effect and reduce the machine's throughput. Additionally, it will reduce the machine's ability to meet minimum air quality standards. There is a maximum rate at which wood can burn. Trying to exceed that rate by adding more air to an air curtain burner causes two major problems:

1. It will cool the fire reducing combustion efficiency which will create more smoke (enriched with more carbon dioxide and oxides of nitrogen). This will begin a circular effect of further reducing the oxygen and further reducing combustion efficiency. The result is your throughput drops and smoke increases.
2. Increasing the air flow beyond design standards will over pressurize the firebox causing larger sized particles to be ejected from the firebox. Besides violating the EPA limits for PM (particulate matter) the larger hotter embers ejected will pose a much greater fire hazard.



S327 FireBox in Operation



S327 FireBox Rear Doors (Open)

IMPORTANT:

Notice how dirt is placed all around the inside bottom rails to close any openings under the skids that may be the result of uneven earthen terrain? This will prevent smoke from escaping. The FireBox must be placed on well-leveled soil (dirt), never on surfaces like concrete slabs, gravel, crushed stones or asphalt.



200 Series Air Curtain Burner with HATZ 4H50 or 3H50 Diesel Engine & Fluid Coupling OPERATING MANUAL

SAFETY CONSIDERATIONS

READ ALL SECTIONS OF THIS MANUAL BEFORE YOU BEGIN BURNING OPERATIONS

The S-Series machine operator is dealing with fire on a daily basis; it is very important that each and every individual involved with the machine be alert and practice very rigid safety precautions.

When you are running the FireBox, you are responsible for assuring that it is operated in the safest possible manner at all times. If you notice something wrong, correct it immediately. If you cannot correct it, find someone who can and/or shut down the machine.

Basic Safety Points:

1. **The unit must be placed on cleared, level ground.**
The unit should be placed on level ground directly on the soil surface (dirt) to facilitate loading, dumping and moving of the unit. The rear doors weigh approximately 2,000 lb. each and should not be opened if the unit is inclined on any axis more than 5 degrees.

2. **The unit should be placed such that no combustible material is stored within a minimum 100 ft. clearance in any direction and never on a concrete pad or gravel stones.**
The S-Series units do not have a bottom and must not be located over combustibles such as dry grass or peat moss which may cause a fire to spread to other areas. It is equally important not to place the standard FireBox on anything other than earthen soil, never on a concrete pad, gravel or crushed stones. There is a good reason for this warning. Concrete or gravel can contain water which the heat in an operating firebox could vaporize quicker than it can be drawn out. This could result in increased vapor pressure that can cause the concrete or stones to explode. Fragments could possibly fly out of the firebox and cause injury or death to persons nearby.

In addition *hot embers* will escape from the firebox and, depending on the wind, will land on the ground around the unit. The unit should not be located within 100 ft. of any stored combustible materials. The waste material to be burned during the day's operation can be staged within the 100 ft. perimeter to facilitate loading. The operator must monitor the loading pile to ensure embers do not ignite the loading pile. The combustible materials to be stored for burning at a later date must be stored outside the 100 ft. perimeter or in accordance with the chart on page 6 of this manual which suggests adjustments for wind speed.

3. **The unit should not be operated when the wind speeds reach 20 mph as the potential to carry hot embers is significantly increased.**
As an operator you should always be aware of wind speed and direction. increased wind speed will affect the integrity of the "air curtain" and will cause hot embers to travel farther. See the wind speed chart regarding suggested set back on page 6.

WARNING:

Watch for, read, and understand the **CAUTION** and **DANGER NOTICES** you will find throughout this operating manual. Failure to heed these warning notices could result in an accident causing property damage and **serious personal injury or death.**



**200 Series Air Curtain Burner with HATZ 4H50 or 3H50 Diesel Engine & Fluid Coupling
OPERATING MANUAL**

4. **NEVER use highly combustible materials to light the unit.**
Highly combustible materials such as gasoline, refined spirits, etc. ignite at an explosive rate which may cause an accident resulting in serious injury or death. The safest method to start the fire in the firebox is to use wood waste materials such as kindling wood. In the absence of these materials or when starting feedstock with a high moisture content, use diesel fuel as an acceptable option if permitted..
5. **NEVER climb on the unit to view or light the fire.**
Use the ladder built into the unit and never go beyond the top step, or use a step ladder or similar platform located at a safe distance from the unit. Do not stand along the rails or on top of the S-Series unit under any circumstance.
6. **Shut the FireBox down in an emergency.**
Stop loading the unit, stop the air flow by shutting down the engine. Dump dirt or sand on to the fire. Water should only be used as a last resort, as it will likely damage the refractory panels.

DANGER:

Do not sit or stand on the roof of the equipment deck or the rails of the FireBox. Falling off the machine or into the firebox will cause an accident resulting in serious injury or death.

WIND SPEED VS. SAFE DISTANCE			
Wind Speed mph	Approximate Safe Distance for:		
	Structures (Houses, etc.) ft.	Woods/Trees ft.	Stored Brush Piles ft.
10	300	150	100
12	300	150	100
14	300	200	150
16	400	250	150
18	400	250	200
20	500	250	200

DANGER:

The above distances serve as a **GUIDELINE ONLY!** You **MUST ALWAYS** observe the down range area regardless of the wind speed.

You must always observe local fire ordinances and directives from the local fire department or other competent authorities.

7. Personal Safety (Personal Protective Equipment – PPE)

Operators must be aware of the following potential hazards:

- a. **Flying hot embers** being released from the fire. Operators or anyone within a 100 ft. radius of the fire should wear appropriate Personal Protective Equipment (PPE) including fire resistant clothing. The ideal outerwear for an operator would include a Nomex jacket, leather gloves, eye protection, hard hat, cotton work jeans and steel toe boots. Operators should never wear synthetic material (i.e., polyester) around a fire as this type of material can melt and cause injury. Additionally, some synthetic materials will support combustion and could be very dangerous around fire. One hundred percent cotton materials would be the minimum, cotton treated with a fire retardant would be better and fire proof materials like Nomex would be best.
- b. **Noise: Ear protection is recommended around the FireBox.** It is a good practice to wear approved ear protection when working in close proximity to the fan and engine.
- c. **Hot Panels:** The backs of the thermo-ceramic panels and parts of the steel structure can reach temperatures as high as 500°F (260°C). Caution should be taken to ensure operator and visitors do not come in contact with these hot areas.
- d. **Wood Ash and Dust will be released** during the FireBox operation, especially during firebox ash cleanout. Operators must wear appropriate Personal Protective Equipment (PPE) like suitable body suits, eye protection, gloves, boots, etc. and in particular face masks like respirators to keep ash that may be suspended in the air from entering their lungs. It must be understood that all persons near an operating FireBox must protect themselves from dust and wood ash as it may be harmful if wood ash and dust enters their airways which may result in injury or death.



Even with proper Personal Protective Equipment (PPE) a person must not step into a firebox without first removing all wood ash residues, embers and unburned feedstock; otherwise an accident may occur which may result in injury or death. There may be hot embers and hot coals hidden within the ash bed and wood ash may be suspended in the air from stirring up the ash bed. This may make it difficult to breathe.

PERSONAL PROTECTIVE EQUIPMENT (PPE) & WOOD ASH CAUTION:

Always wear appropriate Personal Protective Equipment (PPE) while working with the FireBox, especially a breathing apparatus like a respirator while removing wood ash from the firebox and while handling the wood ash.

DANGER: Operators must ensure debris does not build up on the front equipment deck. It must be kept clean at all times during operation to prevent a fire that would damage or destroy the engine and accessories which could result in injury or death to persons nearby.



200 Series Air Curtain Burner with HATZ 4H50 or 3H50 Diesel Engine & Fluid Coupling OPERATING MANUAL

HOW TO SET UP THE FIREBOX

A. POSITIONING THE UNIT

The S-Series units are totally self-contained and ready to use upon delivery to the job site. The FireBox units are built on a skid base that is designed to facilitate dragging the unit into position and to move the unit around the site. The weights of the various units are given in the table on page 2. Ensure that lifting or tow cables are certified for these weights.

With respect to the prevailing wind direction, the unit should be positioned such that the wind comes over the back of the manifold. This is the preferred position. It is also acceptable to have the wind blow into the manifold. It is discouraged, however, to have the wind come from either end of the machine, as this will tend to disrupt the air curtain.

As highlighted under Safety Considerations on page 5, the FireBox must be placed on plain level ground (dirt), and it must not be placed on combustibles like dry grass or peat moss and also never on a concrete pad, gravel, crushed stones or asphalt.

DANGER:

When you tow (drag) the FireBox, especially in soft soil, watch that the dirt does not build up under the panels and lift the panels off the rails. That is why you must never walk inside the FireBox when it is being towed. A dislodged panel could fall on a person inside the firebox which will result in serious injury or death.

Typically, the softer soils will require a longer cable. If the rear of the unit sinks into soft soil while it is being towed, use another vehicle to follow and carry some of the load. If you are still having trouble dragging the unit, try a different length of tow cable. Always stay clear of the tow cable while the dragging operation is underway and wear Personal Protective Gear (PPE).

B. PRE-OPERATION CHECKS:

1. Air filter for cleanliness (VERY IMPORTANT).
2. Engine oil level.
3. Engine coolant level and antifreeze rating.
4. Diesel fuel level.

HOW TO SET UP THE FIREBOX

C. STARTING

Note:

The key can only be removed from the key switch in the OFF position. Turning the key left to the Auto position is not functional and is not used for your HATZ engine.

This Machine is equipped with a “FLUID COUPLING” (Automatic Clutch). It will function automatically. The clutch will spin the air fan at idle which tends to make light up of the fire more difficult and the fire may even be blown out.

Therefore, the engine should be started and warmed up to ensure it is operational then shut down temporarily for the initial light up sequence.



Electronic Control Panel
(Lockable Cover Open)

STARTING Engine

1. Turn key switch right to ON (1) position. The display will be activated.
2. Wait for automatic PREHEAT to complete.
3. Turn key to START, release, once engine is running.
4. Wait for speed to level off at 900 RPM (*Idle*).
5. Shut down engine by setting key switch to OFF position for light up sequence.
6. Turn key switch to START, release, once engine is running.
7. Wait for speed to level off at 900 RPM for *Idle*.
8. Press Throttle Button UP, wait for speed to level off at 1400 RPM.
9. Press Throttle Button UP again to set speed for **Operating Low:**

S220	2200 RPM
S223	2200 RPM



Throttle Button UP & DOWN

10. Press Throttle Button UP again to set speed for **Operating High:**

S220	2500 RPM
S223	2600 RPM

HOW TO SET UP THE FIREBOX

D. SHUT-DOWN

1. Turn key switch to OFF position. The air fan will free-wheel the fluid coupling and spin to stop. This will not cause any engine issues.

WARNING:

Call the Air Burners Customer Support Department for help if the Control Panel throws any fault codes. Call 772-220-7303 or 888-566-3900.



Electronic Control Panel
(Lockable Cover Open)

WARNING:

Your HATZ Diesel Engine is an EPA Tier 4 FINAL certified computer controlled engine. Do not attempt to re-program the Electronic Control Module (ECM) by pressing buttons at random on the control panel. Contact Air Burners Customer Support Department for help, if any errors have occurred.

Call 772-220-7303 or 888-566-3900.

Note: The engine does not require DEF.



Throttle Button UP & DOWN



200 Series Air Curtain Burner with HATZ 4H50 or 3H50 Diesel Engine & Fluid Coupling OPERATING MANUAL

SITE PREPARATION

THE GOALS TO GOOD SITE PREPARATION ARE:

- To place the FireBox for easy access.
- To sort the waste wood pile.
- To organize the inflow of new wood waste.

When locating the FireBox, consider access for your truck and trailer to load and unload the FireBox. Ensure there is enough room to maneuver your truck and trailer.

Consider where the waste piles will be located. We generally recommend two waste piles (explained in the next section).

Consider the predominate wind direction. Hot embers will be escaping from the FireBox during all burning operations.

Consider where and how you will empty the wood ash from the firebox. If you are going to 'drag' the FireBox to empty it, ensure there is room and the soil conditions are not too soft. If you are going to excavate the wood ash out, then consider where you will dump it. In most cases cold wood ash can be reapplied to the land. Check your local ordinances.

Once the FireBox is in position, it is important to place dirt around the inside bottom of the firebox (burn chamber) to close any openings under the skids that may be caused by uneven terrain as shown on [page 4](#). This will prevent smoke and heat from escaping. Pay particular attention to the seal for the forward (engine deck side) wall. Any openings under the panels or forward skid will allow heat from the fire to reach the area below the engine deck. This could cause the engine deck to become hot enough to burn the paint and be a hazard to someone standing on the deck.

DANGER: Never dig a pit in the center of the firebox. This will make it hard to seal the inside of the firebox and the walls of the pit can deteriorate during operation allowing smoke and heat to escape from the firebox or reach the area below the engine deck creating a serious hazard for anyone standing on the deck. This will also void your Air Burners Limited Factory Warranty.

DANGER: Never place the FireBox on combustibles like peat moss or dry grass, and never position it on a concrete pad, gravel or crushed stones or asphalt. For more details, see [Page 7](#).

DANGER: This machine DOES NOT prevent hot embers from escaping. This machine is designed primarily as a pollution control device to reduce the smoke generated from open burning clean wood waste and to reduce the wood waste efficiently.

SITE PREPARATION

Faster operation through staging the wood piles

Air Burners FireBoxes were designed primarily as a pollution control device, but operated correctly they will burn clean wood significantly faster than open burning. To achieve the best throughput, the fire must remain at the highest temperature possible. You achieve this by remembering three rules:

1. Don't smother the fire with a huge load or a load of very dense material.
2. Load "less more often", that is smaller bucket loads more often.
3. Sort out a pile of your best burnable wood, use it to create a hot fire.

The basic principle of operation is not too different from a campfire. You use your best wood to get it started, and if the fire dies down you add some more "Good Wood" to bring it back up. The big difference is that on your campfire you are probably not adding root balls or branches with leaves or pine needles. These are the high moisture content and dense materials that bring the fire temperature down.

The temperature drops (smoke increases) and your burn rate slows down, if you overload the machine with materials that have high moisture content, such as tree branches with leaves and needles, or green branches such as palm fronds. While these are certainly acceptable to burn in the FireBox, you want to add them to a hot fire so they dry out and ignite quickly.

To keep the temperature up and to maintain the highest throughput of feedstock, you should mix the very burnable wood with the less burnable materials throughout the course of the burning operation. The most common way to accomplish this is to stage a pile of the most burnable materials or what we call the "Two Pile System."



S220 FireBox Loading Over Manifold

"If it's burning clean it's burning hot; if there is smoke, you're losing money."



200 Series Air Curtain Burner with HATZ 4H50 or 3H50 Diesel Engine & Fluid Coupling OPERATING MANUAL

SITE PREPARATION

The “Two Pile System”

For an efficient operation you would have two piles:

The **first pile** or “Main Debris” Pile, is the material being generated from the land clearing or forest clearing operation or otherwise collected and is located away from the ember path, but with good access to your loading machinery.

The **second pile** or “Good Wood” Pile is your best and most burnable wood. When you first setup the site, the operator should spend some time sorting through the main debris pile pulling out what appears to be your best, most burnable feedstock. This is the material with which you will start the fire and this material will give you a good hot burning base fire. You will also draw from the “Good Wood” pile throughout the day if you should need to stoke up the fire (more on this in the following sections).

As the FireBox operator is drawing from the main wood debris pile throughout the day, he or she should continue to replenish the “Good Wood” pile as necessary. The “Good Wood” pile only needs to be enough material to stoke-up the fire if needed and enough material to get you started the next day if a “Hot Start” is contemplated.

IMPORTANT WARNING ABOUT BURNING OF PALLETS:

Wooden Pallets, especially spent pallets, burn extremely hot. **DO NOT** load the machine above approximately 3/4 of the height of the firebox (burn chamber). Heat damage to the manifold and other structure may occur which would not be covered under your Limited Factory Warranty.

DANGER:

You must ensure debris does not build up on the equipment front deck. It must be kept clean at all times during operation to prevent a fire that would damage or destroy the engine and accessories and may cause an accident resulting in injury or death to persons standing on the deck.

LOADING AND STARTING THE FIREBOX

LOADING THE FIREBOX

You can load the FireBox from either side, but we recommend loading from the manifold side because (1) it is safest and (2) it tends to increase the life of the manifold, as it reduces the chance for it to be accidentally damaged.



THE GOALS IN STARTING A FIREBOX ARE:

1. To achieve an even fire across the length of the firebox.
2. To start the fire from the bottom of the initial load of wood waste.
3. To build a hot base fire.

There are two methods for lighting the unit: a *cold start* and a *hot start*. A cold start means the FireBox is clean and has no hot coals left from a previous burn. A hot start uses heat from the coals of the previous day's burn.

COLD START

1. The unit should be on level ground and the engine should be off, as the fluid clutch would spin the air fan which would make it more difficult to light the fire and the fire may even be blown out. Ensure, though that you have started the Diesel Engine and warmed it up before switching it off for the light up.
2. To prevent smoke from escaping under the firebox, shovel dirt along the inside bottom edges of the panels. It will only need a couple inches to prevent the smoke from escaping underneath the unit. This is generally only a concern on hard ground, and it usually only lasts for the first hour of burning. After burning for a while the ash will build up and seal off the bottom of the firebox.
3. Load your most burnable material (materials from the "Good Wood" pile as discussed in the previous section) which is the smaller, dryer and cleaner wood, into the firebox to a level about half way up. Ensure that the entire bottom area of the firebox (burn chamber) is covered.
4. If you are permitted to use diesel fuel to assist in the lighting, spray it (approx. 10 gal.) across the top of this first load of wood. Be sure to get some diesel fuel on the wood near the lighting holes in the firebox side and on the wood towards the back. This will help make it easier to light.

DANGER: If you are using an accelerant, first ensure there are NO HOT COALS remaining in the firebox.

DANGER: DO NOT use highly volatile accelerants such as gasoline or kerosene, to light the fire. These fluids ignite almost explosively and may cause injury or death.

LOADING AND STARTING THE FIREBOX

Overview

7. Once you have the smaller material loaded and your accelerant added (if used), load some larger, heavier feedstock on top such as logs or big branches. Load these heavier materials (also from your "Good Wood" pile) to a height just below the manifold nozzles or approx. $\frac{3}{4}$ height for machines burning pallets. This heavier material will help compress the smaller material which will give you a better light-off. If there are large air spaces between the wood debris in the firebox the heat will not build up as quickly and the fire may be more difficult to light.
8. Once burning this material will become your hot base fire to support continued burning. Use your best and driest materials ("Good Wood") for startup as this will form a strong base for continued burning, plus it will start quicker and burn hotter. If you will be burning stumps, it is best to load them after the first hour of burning when the fire is up to full temperature.
8. The level of material in the firebox for light-off should be kept just below the manifold nozzles, except for units burning pallets which should only be loaded up to approximately $\frac{3}{4}$ of the firebox height. Pallets burn extremely hot and loading them to a higher level would tend to warp or destroy the manifold. This heat damage would not be covered by your Limited Factory Warranty.
9. If you are allowed to use diesel fuel as an igniter, it is sometimes helpful to add a second coat to the top load again. ENSURE THERE ARE NO HOT COALS REMAINING IN THE UNIT before adding the accelerant.
10. Your goal is to develop a good hot base fire and to maintain a good hot fire throughout your burning operation. This will give you the cleanest burn and the most throughput.
11. There is always smoke on start-up as all of the material in the firebox contains moisture, compared to later in the burn operation when only the new material you are loading contains moisture. Plus, the air curtain cannot be fully engaged until the fire has strengthened, or you run the risk of blowing out the fire.

IMPORTANT WARNING ABOUT BURNING OF PALLETS:

Wooden Pallets, especially spent pallets, burn extremely hot. DO NOT load the FireBox above approximately $\frac{3}{4}$ of the height of the burn chamber. Heat damage to the manifold and other structure may occur which would not be covered under your Limited Factory Warranty.

DANGER:

NEVER stand on the FireBox like on the front deck roof, air fan or the upper rails, as falling into the firebox will cause a serious accident resulting in injury or death.

LOADING AND STARTING THE FIREBOX

To minimize start-up smoke you can:

- Use your driest wood waste materials.
- Ensure your feedstock has no embedded dirt or sand.
- Use diesel fuel to accelerate the light up, if permitted.

COLD START LIGHTING

1. The engine must be switched off to keep the fluid clutch from rotating the fan, but engine should be warmed up.
2. For best results and quickest light up, start the fire from the bottom because fire will spread upwards much better than it will spread downwards.
3. Use a propane torch (like a weed burner) or oil soaked rags on poles (where allowed) to light the fire.
4. The fire must be started from the access doors in the panels on the manifold side of the unit.

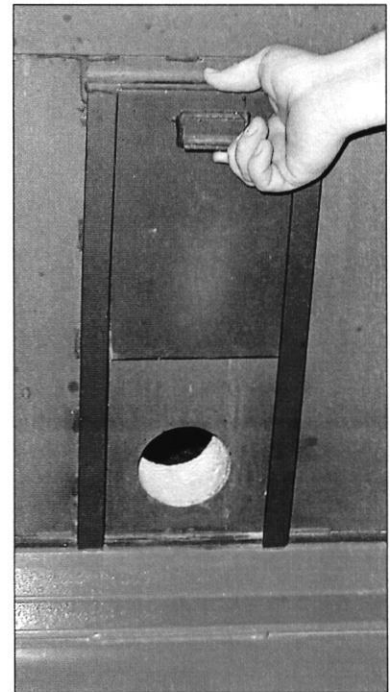

Access Door for Lighting

If you are allowed to use diesel fuel as a starter, let the fire burn until you begin to see wisps of white smoke replacing the wisps of black smoke from the diesel fuel or, if you are using propane torches, wait until the fire has strengthened and flames are reaching the top of the firebox. Then turn on the engine again and set the engine at 1400 RPM. As the fire burns stronger, increase the air up to maximum engine RPM.

Do not increase the air too quickly as you can “blow” the fire out. If you add air and the smoke gets heavier, then reduce the RPM and let the fire “catch-up.” Once the smoke clears up you can increase the air again.

Sometimes it is helpful to “fan” the fire during the start-up phase. You accomplish this by increasing the RPM for 3 to 8 minutes, then decreasing it (i.e. 1400 RPM up to 2500 RPM (S220) or 2600 RPM (S223) and back down to 1400 RPM). This sometimes helps to spread the fire throughout the material. How much air to add and when to add it during startup will vary with the type of materials being burned.



200 Series Air Curtain Burner with HATZ 4H50 or 3H50 Diesel Engine & Fluid Coupling OPERATING MANUAL

LOADING AND STARTING THE FIREBOX

HOT START

A hot start uses the coals from the previous day's burning operation. Depending on how much ash is in the unit, a hot start can be done once or twice before the unit must be emptied. The more ash in the firebox with which you start, the LESS room you have for burning new wood waste materials.

First, ensure there are enough coals remaining to generate enough heat to get the new wood waste materials burning. You CANNOT and MUST NOT add an accelerant, if the waste materials do not light as that would be too dangerous. You can use propane torches in the lighting holes if you have trouble with a hot start. If the material does not light, the firebox must be emptied completely before trying a cold start with the use of an accelerant.

DANGER:

Do not use any kind of accelerant for a Hot Start, as it may ignite unexpectedly and cause an accident resulting in injury or death.

HOT START LIGHTING

Similarly to a cold start you begin with your best and most burnable materials.

1. Load the firebox to about one third or half way with the feedstock from the "Good Wood" pile. The wood should begin burning as soon as you start loading.
2. Set the air fan at 1400 RPM. This should help fan the flames and spread the fire. If you experience heavy smoke then reduce the RPM. Be cautious not to "blow out" the fire.
3. As the fire begins to heat up, increase the RPM.

DANGER:

NEVER stand on the FireBox like on the front deck roof, air fan or the upper rails, as falling off the machine or into the firebox will cause a serious accident resulting in injury or death.



200 Series Air Curtain Burner with HATZ 4H50 or 3H50 Diesel Engine & Fluid Coupling OPERATING MANUAL

HOW TO FEED A FIRE

It will generally take approximately 30 minutes for the fire to build to a point where the temperatures are sufficient for the unit to be operating with minimal smoke.

1. Add material from your "Good Wood" pile slowly for the first hour. It takes about an hour for the fire to reach minimum temperature. Your goal is to achieve an even and hot fire across the unit.
2. For continuous operation the engine RPM is run at full throttle (preset at the factory). If the fire is burning very hot with no smoke the RPM can be reduced to save diesel fuel, but that is very dependent on the waste material.
3. If you get excessive smoke and ash when you load the wood waste while dropping the load through the air curtain, then you may need to turn the RPM down temporarily as you load. This is most likely earlier in the burn operation.
4. Take caution when loading the unit that the material to be burned is not "dumped" into the firebox too quickly causing hot embers to be thrown from the unit.
5. If you have an area in the firebox that is smoking, this indicates the temperature is low in that area. Add material from the "Good Wood" pile to get the fire temperature up. Once that area is burning, add some of the heavier feedstock.
6. The rate at which you load the unit varies depending on moisture content of the wood waste and the temperature of the fire. If you overload the firebox you will notice an increase in white smoke. White smoke is an indication that the temperature is dropping. If the smoke increases stop loading until the fire has caught up. You can also bring the temperature up by adding materials from the "Good Wood" pile.
7. For the highest throughput, load "*LESS MORE OFTEN.*" Smaller loads more often will give the materials a better chance to ignite and will result in your highest throughput of wood waste. Oversized bucket loads may smother the fire for a short period before they ignite; this will slow the burning down and reduce your daily throughput.
8. The load in the firebox should not go higher than the bottom of the manifold (except only approximately $\frac{3}{4}$ firebox height for machines burning pallets). If the material is piled higher, it will begin to break the air curtain and more smoke will escape. This likely will also violate your permit.
9. The fire should be loaded continuously throughout the day, in order to maintain operating temperatures. If the fire is not loaded continuously, the temperature will drop, the throughput will go down and more smoke will escape.

"If it's burning clean it's burning hot; if there is smoke, you're losing money."



200 Series Air Curtain Burner with HATZ 4H50 or 3H50 Diesel Engine & Fluid Coupling OPERATING MANUAL

SHUTDOWN

HOW TO BURN THE FIRE DOWN FOR SHUTDOWN

All loading should stop one or two hours before you intend to put the fire out.

As the fire burns down, maintain the air speed until the firebox begins to smoke. As the smoke increases, reduce the air speed. This will help to reduce the smoke.

The air in the manifold needs air flow, both to accelerate the burn down and to protect the manifold from warping due to excessive heat. **DO NOT shut off the engine (air flow) while there are still flames within 24 in. of the manifold.** Doing so may cause elevated temperatures to warp the manifold, nozzle assembly, etc. Your warranty does NOT cover damage due to excessive heat.

Once the fire has burned down to about one or two feet and flames are not visible near the manifold, it will be safe to shut down the engine and thereby the air by turning the key switch to the OFF position. Make sure the fire is extinguished before you leave the job site. The best way to ensure this is to load dirt or sand into the firebox, **but do not spray the refractory walls with water as this will damage them** (except in a dire emergency).

Some local authorities allow the FireBox to be secured and the embers to smolder all night. There is generally no smoke from this smoldering. Ensure the work site is secured or has a constant security guard to prevent any persons or animals from getting near the FireBox. The inside temperatures of the unit will remain very high most of the night.

If you are not allowed to smolder through the night, then verify the fire inside the firebox is completely out. If it is still burning or smoldering you can either drag the FireBox forward and water down the ash and embers left behind, or you can use sand or dirt to cover the remaining hot spots inside the firebox. **Do not spray the refractory walls with water as this will damage them.** Ensure the fire is completely out and the job site secure before you leave.

DANGER:

NEVER CLIMB ON THE FIREBOX TO VIEW OR LIGHT THE FIRE

Use the ladder built into the FireBox and firmly grasp the provided handle. Never step beyond the top rung. If you use a step ladder or similar platform, locate at a safe distance from the FireBox. Do not stand along the rails or on top of the FireBox (like the front deck roof or air fan) under any circumstance.

Falling into the FireBox or from the FireBox will cause an accident resulting in serious injury or death.

All persons must always wear suitable Personal Protective Equipment (PPE) while near an operating FireBox and during ash clean out and ash handling.

ASH REMOVAL

HOW TO EMPTY THE FIREBOX

We recommend removing the ash every morning before burning operations begin. This will give you maximum capacity in the firebox and the ash will be easier to handle.

The firebox will operate with up to 3 ft. of ash inside, but as the ash gets deeper the efficiency of the unit goes down. Three feet of ash would represent approximately 20 hours of burning. The FireBox should not be run with over 3 ft. of ash inside.

There is only one way to empty the ash out of the electrically powered FireBox, namely, by excavating it out best with an Air Burners ash rake but an excavator could also be used.

ASH RAKE

Air Burners offers an ash removal implement (ash rake) as pictured to the right. It has been designed for each model FireBox. The ash rake is fitted with a universal quick connect faceplate or a blank faceplate for installation on your unique machine (weld it yourself).

You can remove some or all of the ash by reaching in through the rear doors with the ash rake dragging the ash out. **Remember to use**

Personal Protective Equipment (PPE) including a breathing apparatus (i.e., a respirator), otherwise an accident may occur resulting in injury or death. Be also cautious of the remaining hot embers in the ash bed.



It is not required to remove all the ash, if you are planning on a hot restart, generally just a scoop or two with the ash rake is all that is required. This will leave a very hot ember base

DANGER: Ash and dust will be released during the FireBox operation, especially during firebox ash cleanup. Operators must wear appropriate Personal Protective Equipment (PPE) like suitable body suits, eye protection, gloves, boots, etc. and in particular face masks like respirators to keep ash that may be suspended in the air from entering their lungs. It must be understood that all persons near the FireBox must protect themselves from dust and ash as it may be harmful if wood ash and dust enters their airways which may result in injury or death.

Even with proper PPE a person must not step into a firebox without first removing all wood ash residues, embers and unburned feedstock, otherwise an accident may occur which may result in injury or death. There may be hot embers and hot coals hidden within the ash bed and wood ash may be suspended in the air from stirring up the ash bed. This may make it difficult to breathe.



200 Series Air Curtain Burner with HATZ 4H50 or 3H50 Diesel Engine & Fluid Coupling OPERATING MANUAL

ASH REMOVAL

HOW TO EMPTY THE STANDARD FIREBOX

2. EXCAVATING

Excavating the ash out is a common method for daily operations as it allow you to maintain the ember base for restarting a new day's burning operations.

You can remove some or all of the ash by reaching in through the rear doors with an excavator or ash rake and scooping the ash out. **Remember to use an appropriate breathing apparatus like a respirator and other Personal Protective Equipment (PPE) as appropriate, and be cautious of the remaining hot embers.** It is not required to remove all the ash if you are planning on a restart, generally just one "scoop" or two is all that is required. This will leave a very hot ember base from which you begin the new day with a "hot start" as explained previously.

DANGER:

When removing wood ash from the FireBox, be aware of the wind direction and ensure all operators and lookers-on wear appropriate breathing apparatuses like respirators to prevent inhaling any airborne wood ash and other appropriate Personal protective Equipment (PPE)., otherwise an accident may occur that may result in injury or death.

3. DRAGGING

Dragging the unit will allow you to remove all the wood ash for repositioning or when a job is complete, but it will not allow you to maintain the embers for a "hot start."

Open the back doors and cover the wood ash with a thin layer of dirt to minimize ash getting airborne. Connect appropriate strength and length cables or chains to the pad eyes or the pull block on the front of the machine and pull the FireBox forward. The ash will pile up and fall out the back of the unit. Be cautious for the remaining hot embers. Wet the ash pile down, remove unburned chunks of wood and then mix the ash into the native soil or otherwise dispose of it as required by local ordinance.

DANGER:

When removing wood ashes from the firebox, make sure that no hot ashes, embers, burning or hot materials are carried by the wind to places where they could start a fire!



200 Series Air Curtain Burner with HATZ 4H50 or 3H50 Diesel Engine & Fluid Coupling OPERATING MANUAL

TROUBLESHOOTING

1. Fire will not start.

Material in firebox has too much air space. To correct, load heavy material such as stumps to make the lower material pack down. Use torches and light from the bottom so the fire burns up.

2. Fire burning at one end.

Load heavy materials directly on top of the burning area. This causes the flames to fan out in an effort to reach the top of the pile. As the fire begins to spread, keep material piled on top of the flames until the feedstock in the entire firebox is burning.

3. Fire smoking too much.

The most common reason for a smoking fire is too much dirt or dense materials going into the firebox and reducing the heat. You must make sure the wood waste material is free from large amounts of dirt and stones. Load from your "Good Wood" pile to bring the temperature back up.

You may have overloaded the firebox or loaded the firebox too fast. Example: if you only have one ton of material burning you cannot load three tons of material on top of it. The new material will smother the fire. Stop loading and let the fire catch up. The material you are loading may have a very high moisture content. You can either load at a slower rate or mix the wetter material with dryer material.

If you are letting the fire burn down or the wood waste pile in the firebox is less than 3 ft. deep you may need to turn the air down by reducing the engine RPM.

4. Smoke from one area of the firebox.

That area is probably not burning well. Add smaller material from your "Good Wood" pile to this area to help build the fire. As the smoke clears add heavier material.

5. Smoke from under the base rails or bottom of panels.

Loose dirt was not properly shoveled around inside of firebox to seal between panel bottoms and the ground. To fix this, shovel dirt around the outside where the smoke is escaping. Once the ash inside builds up this will stop.

DANGER

You must ensure debris does not build up on the equipment front deck. It must be kept clean at all times during operation to prevent a fire that would damage or destroy the engine and accessories and could cause an accident resulting in injury or death.



200 Series Air Curtain Burner with HATZ 4H50 or 3H50 Diesel Engine & Fluid Coupling OPERATING MANUAL

MAINTENANCE AND CARE

WARNING:

Should any repairs become necessary that require welding on your FireBox, you **MUST** first physically remove the Electronic Control Module (ECM) from the computer controlled Diesel Engine. Follow the instructions on the inside cover page (Page i) of this Operating Manual.

MAINTENANCE AND CARE: See Page 25 and Appendix B for additional details. Also consult the supplied HATZ Engine Service Manual and the MBW Electronic Control Panel Manual.

1. Daily Check List:

- a. Oil level (top off as needed).
- b. Engine coolant level (top off as needed).
- c. Diesel fuel level in fuel tank.
- d. Tap dirt out of air intake housing and check for excessive dirt.
- e. Clean debris off radiator.
- f. Check for fluid leaks.

2. Periodic Maintenance

- a. Change engine oil and oil filter.
- b. Replace fuel filters as needed (Main fuel filter & Racor water separation filter).
- c. Relubricate both (inside) air fan bearings every 3900 hr. of runtime with 15 g (0.53 oz.) of grease. See page 25 for lubricant specifications.
- d. Relubricate fluid coupling bearing every 120 hr. of runtime with 10 g (0.35 oz.) of grease. See page 25 for lubricant specification.
- e. Inspect adjustment of coupler hubs and realign by re-adjusting the engine isolators ("motor mounts") as needed. For instructions see Appendix A.
- f. Check alternator V-belt and adjust as needed.
- g. Arrange for service of fluid coupling with Air Burners Technical Support every 2 years or as needed.

NOTE: A typical manual lever style grease gun supplies approx. 1.1 g (0.039 oz.) of grease per stroke. Calibrate your grease gun by using an appropriate scale like a postal scale. Do this for each type of grease separately: Put the grease amount of 10 strokes onto the scale and divide the result by 10 to get the weight of one (1) stroke or "pump" of your grease gun. Convert ounces to grams if needed.

DO NOT OVERGREASE. DO NOT MIX DIFFERENT TYPES OF LUBRICANTS.
EXCESSIVE GREASING CAN SIGNIFICANTLY REDUCE THE LIFESPAN OF YOUR BEARINGS.

Contact Air Burners, Inc., should you require assistance with any of these necessary maintenance tasks. Send Email to support@airburners.com, call 772-220-7303 or 888-566-3900 (Customer Support).



THERMAL-CERAMIC PATCHING COMPOUND

FOR MINOR REPAIR OF AIR BURNERS REFRACTORY PANELS AND DOORS.

Air Burners Part # 6900-1003 "Thermal-Ceramic Wet Pre-Mix"

*NOTE: This is an air cured product. Reseal unused portion immediately.
Once opened the shelf life is one (1) year.*

Directions:

1. Cracking of the panels is normal as they flex in the heat. Filling the cracks every 6 months or as needed will extend the life of your Thermal-Ceramic Panels.
2. Air Burners patching compound is pre-mixed and ready to use (may require some stirring).
3. Storage: Compound should be stored indoors in a frost-free location.
4. Preparation: the area in and around the damaged area to be patched must be cleaned and brushed to provide the best surface for the compound to adhere. Remove all loose refractory and debris from the area to be patched.
5. Wet the cleaned surface with a light spray or damp cloth.
6. Installation: Using a trowel or similar tool, pack the refractory compound material into cracks and into areas where the refractory is missing. To achieve proper thickness, trim off the excess material using a sharp, flat blade or the side of the trowel.
7. Allow the material to harden overnight before placing the FireBox back into service. After the compound has hardened, operate the FireBox under normal conditions.

NOTE:

This is an air cured product. Reseal unused portion immediately.

WEAR PERSONAL PROTECTIVE EQUIPMENT (PPE):

Always wear appropriate Personal Protective Equipment (PPE) while working with the thermal ceramic patching compound repairing the refractory panels or while performing any other maintenance task on your FireBox.



**200 Series Air Curtain Burner with HATZ 4H50 or 3H50 Diesel Engine & Fluid Coupling
OPERATING MANUAL**

**Parts List for Routine Service of
HATZ 4H50TIC and 3H50TIC Industrial Diesel Engine (Tier 4F)**

Refer to Appendix B "Engine Overview" and the HATZ Service Manual for Additional Engine Service Details
(Engine must be serviced after first 50 hours, then every 500 hours of operation or as needed)

Description	Air Burners P/N	Manufacturer's P/N	Service Interval
Air Filter (Main Element H50)	5000-2338	HATZ 50638200	500 Hours
Air Filter (Secondary Element H50)	5000-2339	HATZ 50638300	500 Hours
Oil Filter H50	5000-2340	HATZ 50638800	500 Hours
Oil Separator H50 (Crank Case Vent)	5000-2341	HATZ 50640500	500 Hours
Combo Main & Pre-Fuel Filter*	5000-3007	HATZ 2147501	500 Hours
Poly-V-Belt (Engine) H50	5000-2344	HATZ 50629401	500 Hours
Fuel/Water Separator Filter	5000-1297	RACOR R20P	As needed
Battery, 12V, Max 120Ah; Max. CCA 800; Min. CCA 750; RC 130	5000-2472	Interstate Batteries 24M-XHD	As needed

Diesel Fuel	Ultra Low Sulfur Fuel Only (ULSD)
Engine Oil	10W40 or 15W40 Diesel Grade
Engine Oil Capacity	4H50: 7.4 qt. (7 L); 3H50: 5.3 qt. (5 L)
Engine Radiator Protection Fluid *	Coolant Fluid must be approved by HATZ, i.e. Havoline XLC (OF02), Havoline XLC+B, Castrol Radicool SF, Exxon Mobil Delvac ELC Coolant
Bearing Lubricant	Air Fan & Fluid Clutch: SKF LGMT 3IN/18
DEF and DPF **	Not required (Engine meets US EPA Tier 4 Final and EU 97/68 Stage 3 B)
Fuel Tank Capacity	Minimum 58 gal. (220 L)

Consult FireBox Operating Manual for engine-to-air fan coupler service and adjustment.

* Contact Air Burners Customer Service Dept. for complete list of HATZ approved Radiator Protection Fluids.

** DEF = Diesel Exhaust Fluid DPF= Diesel Particulate Filter

**Contact Air Burners, Inc., should you require assistance with any maintenance task.
Email: support@airburners.com
Phone: 772-220-7303 or 888-566-3900
(Customer Support)**

LIFTING POINTS & STAIR GUARD

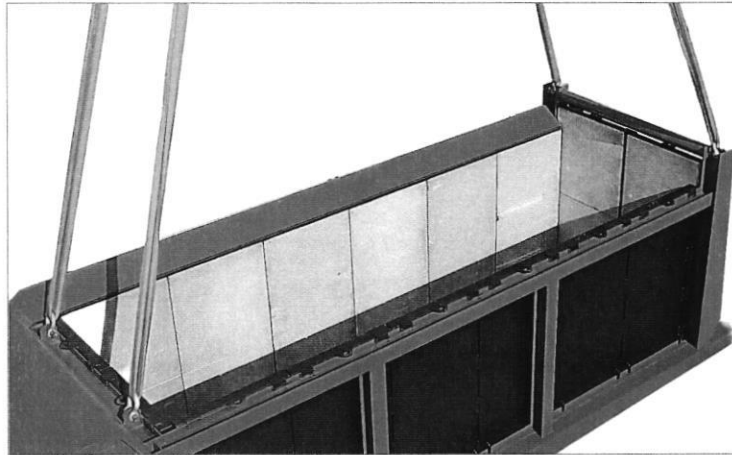

WARNING:

There are four designated lifting pad eyes for lifting all FireBox units by crane, two on each side. **Only lift by attaching properly rated straps or cables to these four pad eyes.** Their locations are marked with yellow lifting point labels with *up-arrows*).

Approx. Weight: S223: 40,350 lb. (18,300 kg); S220: 36,650 lb. (16,620 kg)

WARNING:

The Stair Guard is shipped in place secured with a bolt and nut (red circle in photo to right). The bolt should be replaced with a suitable padlock, before the FireBox is placed into service.

Only authorized personal must be allowed to remove the stair guard and persons wearing suitable Personal Protective Equipment (PPE) using the built-in stairs must hold firmly onto the handle and never step beyond the top rung.



APPENDIX A CHECKING COUPLING ALIGNMENT

This Technical Memorandum covers FireBox Models equipped with Dodge Raptor Couplings. The S327 and S330 FireBoxes use Size E30 (Air Burners Replacement Part Number 5000-2120) and all other FireBox models use Size E20 (Air Burners Replacement Part Number 5000-5123). Certain FireBoxes equipped with electric motors (mostly 300 Series) are also fitted with Dodge Raptor couplings. The general coupling information in this Technical Memorandum applies to them also.

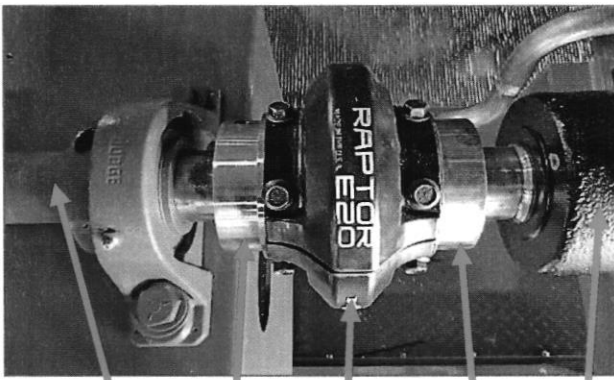

FAN SHAFT HUB ELEMENT HUB FLUID CLUTCH

The coupling shown above is an E20 with the protective guard removed

TOOLS REQUIRED

Coupling hubs should be aligned using straight edges or calipers. Laser alignment tools, or other precision alignment equipment can be used but are not required.

Tools

1. Two open-end wrenches, 3/4"
2. Torque wrench
3. Sockets/wrenches, 9/16" & 7/16"
4. Straight Edge Ruler or Calipers

WEAR SUITABLE PERSONAL PROTECTIVE EQUIPMENT (PPE).

Step 1 Preparation

1. Lock out engine/motor to prevent accidental start which could cause injury.
2. Remove the protective metal guard (Not shown in image above) from fan.
3. Take off the element by removing the Grade A bolts holding the two halves together. Bolts should be used only one time. All bolts use thread locking patches.
4. If any coupling adjustments are required, be prepared to realign the engine by adjusting the four engine isolators until the measurements of Steps 2, 3 and 4 are achieved.

Step 2 Verify Gap Between Hubs

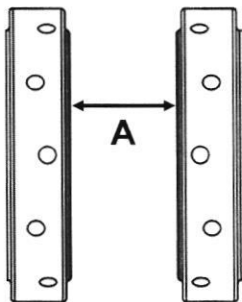

1. Measure the distance "A" between the hubs with calipers or other appropriate tool.
2. If needed, set distance "A" as follows:

GAP MEASUREMENT "A"		
E20	2.46"	62mm
E30	2.55"	65mm

APPENDIX A CHECKING COUPLING ALIGNMENT

Step 3 Verify Angular Alignment of Hubs

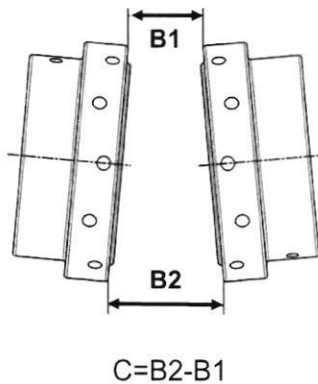

1. Measure the distance "B" between the hubs with calipers or other appropriate tool at four places on the outer diameter of the hub 90° apart.
2. Use the "B2" and "B1" measurements to calculate "C" by subtracting the smaller measurement from the larger number, and do this for each of the 90° apart planes.
3. Adjust the engine isolators until the "C" measurements of both planes do not exceed these Angular Values:

ANGULAR VALUE "C"		
E20	0.235"	6mm
E30	0.284"	7.2mm

Step 4 Verify Parallel Alignment of Hubs

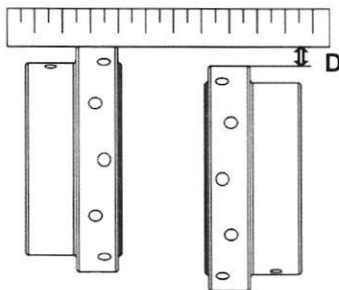

D is the distance between straight edge and lower outer hub edge

1. Check parallel misalignment by placing a straight edge across the outside diameter of the hubs and measuring the gap between the straight edge and the hub at four locations 90° apart.
2. Adjust the engine isolators until the "D" measurements do not exceed these Parallel Values.

PARALLEL VALUE "D"		
E20	0.188"	4.8mm
E30	0.188"	4.8mm

Step 5 Element Installation

1. Place first element half on hubs and hand-tighten the flange head bolts. When tightening the bolts, start at the center bolt hole and then install the bolts on the neighboring holes.
2. Place the second half of the element on the hubs and follow the same procedure. Hand-tighten the flange head bolts.
3. Use a torque wrench to tighten all fasteners for the E20 and E30 to these torque values (same for both):

ELEMENT BOLT TORQUE VALUES				
	Bolt Size	In-lbs.	ft-lbs.	Nm
E20 & E30	3/8	502	42	57

**APPENDIX B
HATZ ENGINE OVERVIEW (3H50 & 4H50)**

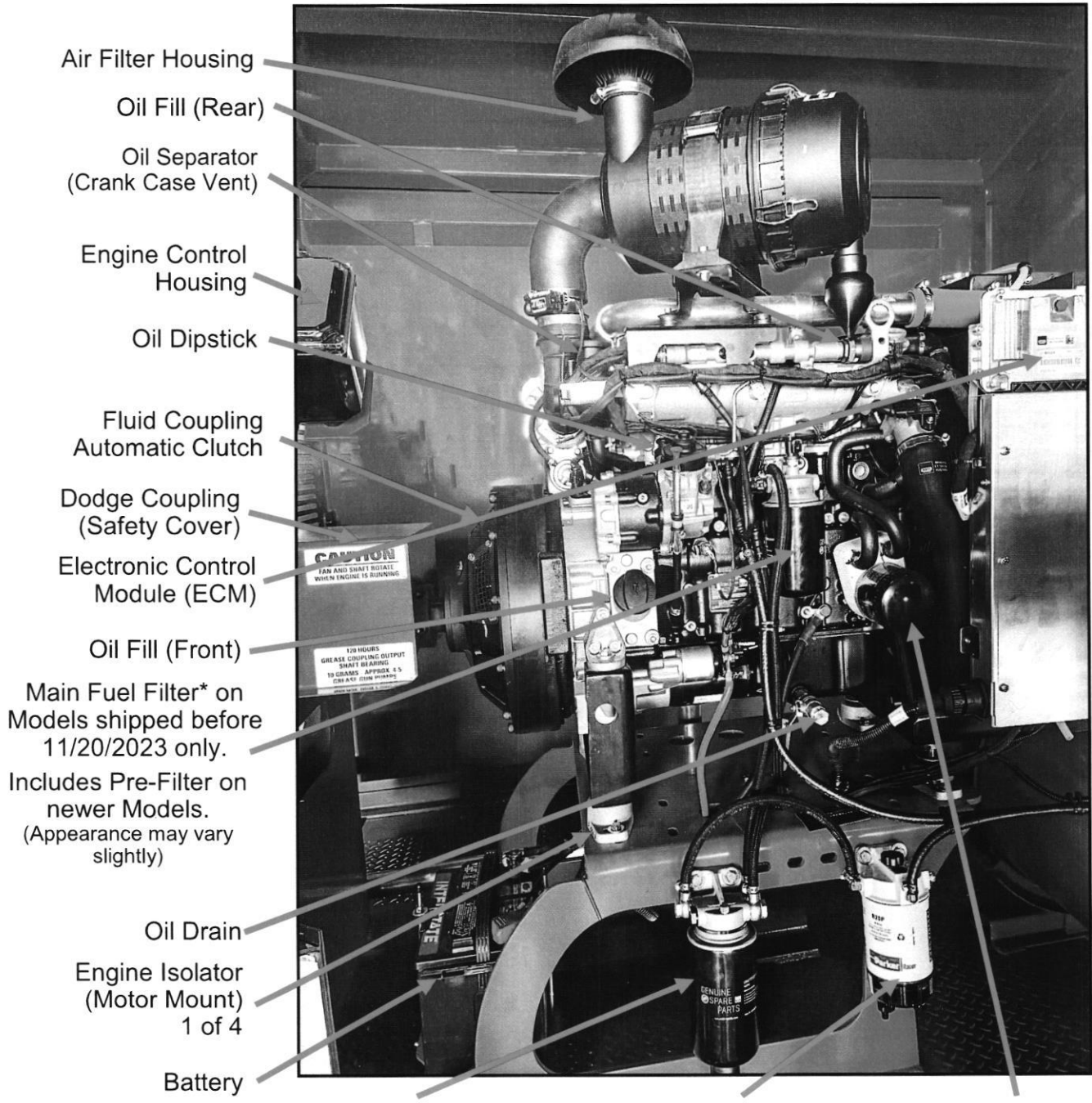

- Air Filter Housing
- Oil Fill (Rear)
- Oil Separator (Crank Case Vent)
- Engine Control Housing
- Oil Dipstick
- Fluid Coupling Automatic Clutch
- Dodge Coupling (Safety Cover)
- Electronic Control Module (ECM)
- Oil Fill (Front)
- Main Fuel Filter* on Models shipped before 11/20/2023 only. Includes Pre-Filter on newer Models. (Appearance may vary slightly)
- Oil Drain
- Engine Isolator (Motor Mount) 1 of 4
- Battery

*Pre-Fuel Filter - only on Models shipped before 11/20/2023

RACOR Fuel-Water Separator

Oil Filter

NOTE: On FireBoxes shipped after November 20, 2023, the HATZ Diesel Engine fuel filter system was simplified by combining the main filter and pre-filter into a single unit.

BOARD OF COUNTY COMMISSIONERS OF BRADFORD COUNTY, FLORIDA

AGENDA ITEM INFORMATION SHEET

DATE:

April 7, 2026

AGENDA ITEM

Discussion of “Douglas” Building Property Options
A. Potential Lease with Bradford County Sheriff’s Office for the purpose of installation of a temporary ICE detention facility.
B. Other Lease or Marketing Options

DEPARTMENT:

County Manager

PURPOSE:

Discussion to provide staff direction regarding the property.

BOARD OF COUNTY COMMISSIONERS OF BRADFORD COUNTY, FLORIDA

AGENDA ITEM INFORMATION SHEET (AIIS)

DATE OF MEETING: April 7, 2026

AGENDA ITEM _____: Appoint a citizen member to serve on the Bradford County Value Adjustment Board.

OFFICE: Clerk of Court - VAB

PURPOSE:

Please be advised that the governing body of the county – BOCC – will need to appoint a new citizen member to replace Matthew Carlton who will no longer be able to serve on the VAB. A citizen member must not be a member or employee of any taxing authority in Florida, or represent owners, property appraisers, tax collectors or taxing authorities in any administrative or judicial review of property taxes.

BOARD OF COUNTY COMMISSIONERS OF BRADFORD COUNTY, FLORIDA

AGENDA ITEM INFORMATION SHEET (AIIS)

DATE OF MEETING: April 7, 2026

AGENDA ITEM: Notice of lands available for taxes. Direction needed from the board on its desire to purchase or waive its right to purchase the available land for taxes. Original opening bid amount - \$3,568.65. Taxes, recording fees, and interest will be applied to sell amount.

DEPARTMENT: Clerk's Office

JUSTIFICATION:

Per. F.S. 197.502(7): "On county-held or individually held certificates for which there are no bidders at the public sale and for which the certificate holder fails to timely pay costs of resale or fails to pay the amounts due for issuance of a tax deed within 30 days after the sale, **the clerk shall enter the land on a list entitled "lands available for taxes" and shall immediately notify the county commission that the property is available. During the first 90 days after the property is placed on the list, the county may purchase the land for the opening bid or may waive its rights to purchase the property.** Thereafter, any person, the county, or any other governmental unit may purchase the property from the clerk, without further notice or advertising, for the opening bid, except that if the county or other governmental unit is the purchaser for its own use, the board of county commissioners may cancel omitted years' taxes, as provided under s. 197.447. Interest on the opening bid continues to accrue through the month of sale as prescribed by s. 197.542".

On 3/25/26, an email was sent to each commissioner from the clerk's office advising you of the available land for sale with instructions to discuss your interest in purchasing or waiving your right to purchase the land available for taxes during your April 7, 2026 county commission meeting.

Denny Thompson,
Clerk & Comptroller
Bradford County

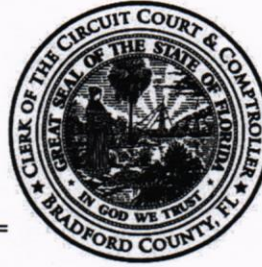

March 25, 2026

To: Bradford County Board of County Commissioners

Subject: Lands Available for Taxes

Dear County Commissioners:

Please be advised that on December 17, 2025, our office conducted a tax deed sale on the following property which did not sell.

- Parcel Number: 01195-0-00000
- Certificate Number: 313
- Certificate Holder: Mikon Financial Services, Inc. and Ocean Bank
- Opening Bid: \$3,568.65 (taxes, recording fees, and interest fees will apply to sell price)

As such, and in accordance with F.S. 197.502(7), our office must enter the land on a list entitled "lands available for taxes" and shall immediately notify the county commission that the property is available. During the first 90-days after the property is placed on the list, the county may purchase the land for the opening bid or may waive its right to purchase the property. Thereafter, any person, the county, or any other governmental unit may purchase the property from the clerk, without further notice or advertising, for the opening bid, except that if the county or other governmental unit is the purchaser for its own use, the board of county commissioners may cancel omitted years' taxes, as provided under s. 197.447. Interest on the opening bid continues to accrue through the month of sale as prescribed by s. 197.542.

During your April 7, 2026 county commission meeting, please be prepared to discuss as a board your desire to either purchase the land available for taxes or waive your right to purchase.

***Buyer Beware: The buyer is responsible for and must conduct its own research concerning the property. All parcels are sold in "as-in" condition and are conveyed by a tax deed. No guarantees are made about the parcel's condition, title quality, accessibility, or size. ***

In the event you have any questions or concerns, please do not hesitate to contact me.

Respectfully,

Rachel Rhoden

Bradford County Property Appraiser

Kenny Clark, CFA

2026 Working Values
updated: 3/12/2026

Parcel: << 01195-0-00000 (5168) >>

Owner & Property Info

Result: 1 of 1

Owner	CORNWALL THELMA (DEC) ET AL % JESSIE CORNWALL (SON) 1469 NW CR 125 LAWTEY, FL 32058		
Site	1469 NW CR 125, LAWTEY		
Description*	14 5S 22 COM INT OF N LINE OF SE 1/4 OF SE 1/4 & W R/W OF 301, W500', S18°40'W 869.1' TO POB. S18°W 440' TO N LINE OF SR125, W243' N420', E386' TO POB.		
Land Area	3.14 AC (see Acreage Note in the Land Breakdown section below)	S/T/R	14-5S-22E
Use Code**	SINGLE FAMILY (0100)	Tax District	SRWMD (6)

*The Description above is not to be used as the Legal Description for this parcel in any legal transaction.
**The Use Code is a FL Dept. of Revenue (DOR) code and is not maintained by the Property Appraiser's office. Please contact your city or county Planning & Zoning office for specific zoning information.

Property & Assessment Values

2025 Certified Values		2026 Working Values	
Mkt Land	\$58,540	Mkt Land	\$58,540
Ag Land	\$0	Ag Land	\$0
Building	\$31,817	Building	\$5,682
XFOB	\$0	XFOB	\$0
Just	\$90,357	Just	\$64,222
Class	\$0	Class	\$0
Appraised	\$90,357	Appraised	\$64,222
SOH/10% Cap	\$40,936	SOH/10% Cap	\$0
Assessed	\$49,421	Assessed	\$64,222
Exempt HX HB	\$25,000	Exempt	\$0
Total	county:\$24,421	Total	county:\$64,222
Taxable	other:\$24,421 school:\$24,421	Taxable	other:\$64,222 school:\$64,222

NOTE: Property ownership changes can cause the Assessed value of the property to reset to full Market value, which could result in higher property taxes.

Aerial Viewer Google Maps



Sales History

Sale Date	Sale Price	Book/Page	Deed	V/I	Qualification (Codes)	RCode
3/6/2000	\$0	0000 / 0000	DC	I	U	
9/1/1972	\$0	0000 / 0000	DC	I	U	11
8/25/1967	\$0	065 / 263	N/A	I	U	
5/11/1964	\$0	042 / 185	N/A	I	U	
5/8/1962	\$0	027 / 509	N/A	I	U	

Building Characteristics

Bldg Sketch	Description*	Year Blt	Base SF	Actual SF	Bldg Value
Sketch	SINGLE FAM (0100)	1950	720	1072	\$5,682

*Bldg Desc determinations are used by the Property Appraisers office solely for the purpose of determining a property's Just Value for ad valorem tax purposes and should not be used for any other purpose.

Extra Features & Out Buildings

Code	Desc	Year Blt	Value	Units	Dims
NONE					

Land Breakdown

Code	Desc	* Units	Adjustments	Eff Rate	Land Value
000100	SFR 35000 (MKT)	1.000 AC	1.0000/1.0000 1.0000/ /	\$35,000 /AC	\$35,000
000115	SFR ACRES 11000 (MKT)	2.140 AC	1.0000/1.0000 1.0000/ /	\$11,000 /AC	\$23,540

[Acreage Note](#): When there is an 'FF' calculation in the *Units column, the acreage in the Land Area field above may not reflect the total amount of acreage for the parcel. Please feel free to contact our office for more information.

Search Result: 1 of 1

The information presented on this website was derived from data which was compiled by the Bradford County Property Appraiser solely for the governmental purpose of property assessment. This information should not be relied upon by anyone as a determination of the ownership of property or market value. The GIS Map image is not a survey and shall not be used in a Title Search or any official capacity. No warranties, expressed or implied, are provided for the accuracy of the data herein, its use, or its interpretation. This website was last updated: 3/12/2026 and may not reflect the data currently on file at our office.

TDA NUMBER: 629TDA

PARCEL NUMBER:R 01195-0-00000

Legal Description:

Commence at the intersection of the North line of the Southeast quarter (SE1/4) of the Southeast quarter (SE1/4) of Section 14, Township 5 South, Range 22 East and run West 500 feet, thence South 18 degrees and 40 minutes West 869.1 feet for point of beginning. Thence continue South 18 degrees West 440 feet to North line of State Road No. 125. Thence West 243 feet along said State Road No. 125, 243 feet, thence North 420 feet, thence East 386 feet to point of beginning, containing 3.14 acres more or less and lying in the Southeast quarter (SE1/4) of the Southeast quarter (SE1/4) of Section 14, Township 5 South, Range 22 East.

CERTIFICATION OF TAX DEED APPLICATION

Sections 197.502 and 197.542 , Florida Statutes

513

07/19

Page 1 of 2

2025-TD-0006

Part 1: Tax Deed Application Information			
Applicant	MIKON FINANCIAL SERVICES, INC	Application Date	04/22/2025
Property description	01195-0-00000 14 5S 22 COM INT OF N LINE OF SE1/4 OF SE1/4 & W R/W OF 301, W500', S18*40'W 869.1' TO POB . S18*W 440' TO N LINE OF SR12 5, W243' N420', E386' TO POB.	Certificate #	313
		Date certificate issued	06/01/2023

FILED CLERK BRADFORD CO
2025 AUG 19 11:43

Part 2: Certificates Owned by Applicant and Filed with Tax Deed Application				
Column 1 Certificate Number	Column 2 Date of Sale	Column 3 Face Amount of Cert	Column 4 Interest	Column 5 Total (Column 3 + Column 4)
313	06/01/23	483.14	24.16	507.30
Part 2 Total:				507.30

Part 3: Other Certificates Redeemed by Applicant (Other than County)					
Column 1 Certificate Number	Column 2 Date of Sale	Column 3 Face Amount of Cert	Column 4 Tax Collectors Fee	Column 5 Interest	Total (Col3 + Col4 + Col5)
333	06/01/24	558.67	6.25	44.80	609.72
Part 3 Total:					609.72

Part 4: Tax Collector Certified Amounts (Lines 1-7)	
1. Cost of all Certificates in Applicant's Possession and other certificates redeemed by applicant (*Total of Parts 2 + 3 above)	1117.02
2. Delinquent taxes paid by the applicant	500.47
3. Current taxes paid by the applicant	.00
4. Property information report fee	200.00
5. Tax Deed Application Fee	75.00
6. Interest accrued by tax collector under s.197.542, F.S. (see Tax Collector Instr.)	113.55
7. Total Paid (Lines 1-6)	2006.04

I certify the above information is true and the tax certificates, interest, property information report fee, and tax collector's fees have been paid, and that the property information statement is attached

BRADFORD County, Florida

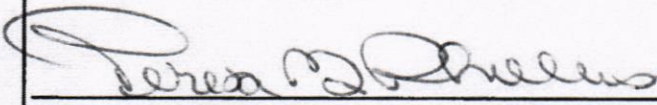

Signature Tax Collector or Designee

Date Aug 13, 2025

Send the certification to the Clerk of Court by 10 days after the date signed. See instructions on Page 2

Part 5: Clerk of Court Certified Amounts (Lines 8 - 15)	
8. Processing tax deed fee	
9. Certified or registered mail charge	
10. Advertising charge (see s.197.542, F.S.)	
11. Recording fee for certificate of notice	
12. Sheriff's Fees	
13. Interest (see Clerk of Court Instructions, page2)	
14. Total Paid (line 8-13)	
15. Plus one-half of the assessed value of homestead property, if applicable under s.197.502(6)(c),F.S	
16. Statutory opening bid (total of Lines 7, 14 and 15, if applicable)	
<p style="text-align: right;">Date _____, 20____</p> <p style="text-align: center;">_____ Signature Tax Collector or Designee</p>	

INSTRUCTIONS

Tax Collector (complete Parts 1-4)

Part 2: Certificates Owned by Applicant and Filled with Tax Deed Application
Enter the Face Amount of Certificate in Column 3 and the Interest in Column 4 for each certificate number. Add Columns 3 and 4 and enter the amount in Column 5

Part 3: Other Certificates Redeemed by Applicant (Other than County)
Total. Add the amounts in Columns 3, 4 and 5

Part 4: Tax Collector Certified Amounts (Lines 1-7)

Line 1. enter the total of Part 2 plus the total of Part 3 above.

Total Paid, Line 7: Add the amounts of Lines 1-6
Line 6, Interest accrued by tax collector.
Calculate the 1.5 percent interest accrued from the month after the date of application through the month this form is certified to the clerk. Enter the amount to be certified to the clerk on Line 6. The interest calculated by the tax collector stops before the interest calculated by the clerk begins.
See Section 197.542, F.S., and Rule 12D
13.060(3), Florida Administrative Code.

The tax collector's interest for redemption at the time of the tax deed application is a cost of redemption, which encompasses various percentages of interest on certificates and omitted or delinquent taxes under Section 197.502, F.S. This interest is calculated before the tax collector calculates the interest in Section 197.542, F.S.

Attach certified statement of names and addresses of persons who must be notified before the sale of the property. Send this form and any required attachments to the Clerk of Court within 10 days after it is signed.

Clerk of Court (complete Part 5)

Line 13: Interest is calculated at the rate of 1.5 percent per month starting from the first day of the month after the month of certification of this form through the last day of the month in which the sale will be held. Multiply the calculated rate by the total of Line 7, minus Line 6, plus Lines 8 through 12. Enter the amount on Line 13.
Line 14: Total Paid Enter the total of lines 8-13. Complete Lines 15-16, if applicable.



Teresa G. Phillips, CFC
BRADFORD COUNTY TAX COLLECTOR

Denny Thompson, Clerk of the Circuit Court
Bradford County, Starke Florida 32091

Reference: TDA #629 PARCEL#01195-0-00000
Applicant: MIKON FINANCIAL SERVICES, INC & OCEAN BANK

Following are the names and addresses of all persons you are required to notify prior to the tax deed sale.

Legal Titleholder:
SEE ATTACHED

Property Address:
1469 NW CR 125
Lawtey FL 32058

Additional Name & Address:

Persons to whom the property was last assessed:
Thelma Cornwall (Dec) ET AL
%jessie Cornwall (Son)
1469 NW CR 125
Lawtey FL 32058

Liens: NONE

Also Lien:
NONE

Mortgagees:
NONE

Special Assessments:
NONE

This property is:
Not Vacant
Homestead
NO-AG

Property Taxes:
2025 TAXES DUE NOV.

Certified this 12 day of Aug, 2025

A handwritten signature in black ink, appearing to read "Teresa G. Phillips".

Teresa G. Phillips, Tax Collector

904-966-6240
904-966-6235

904-966-6246
904-966-6328

KEYSTONE HEIGHTS FL
904-368-3950

STARKE, FLORIDA 32091

P.O. Box 969
945 N. TEMPLE AVE · SUITE B

BRADFORDTAXCOLLECTOR.COM
teresa_phillips@bradfordcountyfl.gov

P: 904-966-6274
F: 904-964-9063

PARCEL#01195-0-00000

TDA 629

LEGAL TITLEHOLDER:

Stella Wilkerson as to Life Estate &

Leon Wilkerson

Geneva Baxley

Mamie Barrett

Mary Ballentine

Thelma Cornwall

Corine Dickerson

Bryant Wilkerson

Rt 1 Box 218

Lawtey FL 32058

Parcel#01195-0-00000
TDA629

Contiguous Owners:

01196-0-00200
WILKERSON JAMES L
PO BOX 299
LAWTEY, FL 32058-0299

01196-0-00300
BURNS DANIEL P
1430 NW 236TH ST
LAWTEY, FL 32058

01190-0-00000
ALEXANDER AMBER
1539 FLOYD JOHNS RD
JACKSONVILLE, FL 32234

01193-0-00000
WILKERSON DAVID ET AL
PO BOX 574
LAWTEY, FL 32058

01194-0-00000
MOTEL ECONOMY INN
555 GOVERNMENT ST
MOBILE, AL 36602

BOARD OF COUNTY COMMISSIONERS OF BRADFORD COUNTY, FLORIDA

AGENDA ITEM INFORMATION SHEET

DATE: April 7, 2026

AGENDA ITEM Introduction of Bernadette Fisher, Zoning Director

DEPARTMENT: County Manager